

TS-RTXM290-403 100Gb/s CFP Optical Transceiver

PRODUCT FEATURES

- Angled LC receptacle optical interface
- Single +3.3V power supply
- Hot-pluggable
- Operating optical data rate up to 112Gbps
- Operating electrical serial data rate up to 10.3125Gb
- 10 parallel electrical serial interface
- Transmission distance up to 40km
- AC coupling of CML signals
- 1310 nm window cooled EA-DFB LD
- PIN ROSA
- Built in SOA
- Low power dissipation(Max:24W)
- Built in digital diagnostic function
- Operating case temperature range:0°C to 70°C
- Compliant with RoHs
- MDIO Communication Interface



APPLICATIONS

- OTN-OTU4
- Switch to switch interface
- Switch to rounter interface
- P to P Access Network

STANDARD

- Compliant with IEEE 802.3ba

- Compliant with CFP MSA hardware specification
- Compliant with CFP MSA management specification
- Compliant with ITU-T G.709/Y.1331
- Compliant with RoHS&WEEE

Absolute Maximum Ratings

Parameter	Symbol	Unit	Min	Max
Storage Temperature Range	T _s	°C	-40	+85
Relative Humidity	RH	%	5	95
Power Supply Voltage	V _{cc}	V	-0.5	+3.6

Recommended Operating Conditions

Parameter	Symbol	Unit	Min	Typ	Max
Operating Case Temperature Range	T _c	°C	0		70
Power Supply Voltage	V _{cc}	V	3.2	3.3	3.4
Data rate		Gb/s		103.125	112

Specifications *(tested under recommended operating conditions, unless otherwise noted)*

Parameter	Symbol	Unit	Min	Typ	Max	Notes	
Voltage Supply Electrical Characteristics							
Supply Current	$\frac{\text{Tx Section}}{\text{Rx Section}}$	I _{cc}	A	-	-	7.5	1
Power Supply Noise		V _{rip}				2% 3%	DC-1MHz 1-10MHz
Dissipation	Class3	P _w	W			24	
Low Power Dissipation		P _{low}	W			2	
Inrush Current	Class3	I _{inrush}	mA/usec			100	
Turn-off Current		I _{turnoff}	mA/usec	-100			
Different Signal Electrical Characteristics							
Single Ended Data Input Swing			mV	20	-	525	
Single Ended Data Output Swing			mV	180	-	385	
Differential Signal Output Resistance			Ω	80		120	
Differential Signal Input Resistance			Ω	80		120	
3.3V LVCMOS Electrical Characteristics							
Input High Voltage	3.3V _{IH}	V	2.0	-	V _{cc} +0.3		
Input Low Voltage	3.3V _{IL}	V	-0.3	-	0.8		
Input Leakage Current	3.3I _{IN}	uA	-10	-	+10		
Output High Voltage (I _{OH} =100uA)	3.3V _{OH}	V	V _{cc} -0.2	-	-		
Output Low Voltage (I _{OL} =100uA)	3.3V _{OL}	V			0.2		
Minimum Pulse Width of Control Pin Signal	t _{CNTL}	us	100				
1.2V LVCMOS Electrical Characteristics							

Input High Voltage	1.2VIH	V	0.84	1.5	
Input Low Voltage	1.2VIL	V	-0.3	0.36	
Input Leakage Current	1.2IIN	uA	-100	+100	
Output High Voltage	1.2VOH	V	1.0	1.5	
Output Low Voltage	1.2VOL	V	-0.3	0.2	
Output High Current	1.2IOH	mA		-4	
Output Low Current	1.2IOL	mA	+4		
Input Capacitance	Ci	pF		10	
Optical transmitter Characteristics					
Signaling Rate for Each Lane		Gbps	-	25.78125	28
Four Lane Wavelength Range	$\lambda 1$	nm	1294.53	1295.56	1296.59
	$\lambda 2$		1299.02	1300.05	1301.09
	$\lambda 3$		1303.54	1304.58	1305.63
	$\lambda 4$		1308.09	1309.14	1310.19
Side Mode Suppression Ratio	SMSR	dB	30		-
Total Average Launch Power	Pt	dBm	-		8.9
Average Launch Power for Each Lane	Pa	dBm	-2.9		2.9 2
Optical Modulation Amplitude for Each Lane	OMA	dBm	0.1		4.5 3
Transmitter and Dispersion Penalty for Each Lanes		TDP			2.5
Average Launch Power of Off Transmitter for Each Lanes	Poff	dBm	-		-30
Extinction Ratio	EX	dB	8		
RIN _{20OMA}		dB/Hz			-130
Optical Return Loss Tolerance		dB			20
Transmitter Reflectance		dB			-12 4
Eye Diagram	Compliant with IEEE 802.3ba-LR4				
Optical receiver Characteristics					
Receive Rate for Each Lane		Gbps	-	25.78125	28
Four Lane Wavelength Range	$\lambda 1$	nm	1294.53	1295.56	1296.59
	$\lambda 2$		1299.02	1300.05	1301.09
	$\lambda 3$		1303.54	1304.58	1305.63
	$\lambda 4$		1308.09	1309.14	1310.19
Overload Input Optical Power	Pmax	dBm	5.5		5
Average Receive Power for Each Lane	Pin	dBm	-20.9		4.5 6&7
Receive Power In OMA for Each Lane	PinOMA	dBm	-		4.5
Difference in Receive Power between Any Two Lanes		dBm	-		4.5
Receiver Sensitivity in OMA for Each Lane	SOMA	dBm			-19.4 8
Stressed Receiver Sensitivity in OMA for Each Lane		dBm			-17.9 9&10

Note1. The supply current includes CFP module's supply current and test board working current.

Note2. Average launch power ,each lane(min) is informative and not the principal indicator of signal strength. A transmitter with launch power below this value cannot be compliant; however, a value above this does not ensure compliance

Note3. Even if the TDP<1dB, the OMA(min) must exceed this value

Note4. Transmitter reflectance is defined looking into the transmitter

Note5. The receiver shall be able to tolerate , without damage, continuous exposure to an optical input signal having this average power level

Note6. The average receive power , each lane (max) for 100GBASE-ER4 is larger than the 100BASE-ER4

transmitter value to allow compatibility with 100BASE-LR4 units at short distances

Note7. Average receive power, each lane (min) is informative and not the principal indicator of signal strength. A received power below this value cannot be compliant; however, a value above this does not ensure compliance

Note8. Receiver sensitivity (OMA), each lane (max) is informative

Note9. Measured with conformance test signal at TP3 for BER=10⁻¹²

Note10. conditions of stressed receiver sensitivity test: vertical eye closure penalty for each lane is 1.8dB;stressed eye J2 jitter for each lane is 0.3UI; stressed eye J9 jitter for each lane is 0.47UI.

Hardware Control Pin

The CFP Module support real-time control functions via hardware pins, listed in the following table: Hardware Control Pins

Hardware Control Pins

Pin#	Symbol	Description	I/O	Logic	H	L	Pull-up/down
30	PRG_CN TL1	Programmable Control 1 MSA Default:TRXIC_RSTn , TX&RX ICs reset, "0":reset;"1"	I	3.3V LVCMO S	per CFP Management Interface Specification	MSA	Pull-Up Note1
31	PRG_CN TL2	Programmable Control 2 MSA Default :Hardware Interlock LSB	I	3.3V LVCMO S			Pull-Up Note1
32	PRG_CN TL3	Programmable Control 3 MSA Default:Hardware Interlock MSB	I	3.3V LVCMO S			Pull-Up Note1
36	TX_DIS	Transmitter Disable	I	3.3V LVCMO S	Disable	Enable	Pull-Up Note1
37	MOD_LO PWR	Module Low Power Mode	I	3.3V LVCMO S	Low Power	Enable	Pull-Up Note1
39	MOD_RS Tn	Module Reset(Invert)	I	3.3V LVCMO S	Enable	Reset	Pull-Down Note2

Note1: Pull-Up resistor (4.7KOhm to 10 KOhm) is located within the CFP module

Note2: Pull-Down resistor (4.7KOhm to 10 kOhm) is located within the CFP module

Hardware Alarm Pins

The CFP Module supports alarm hardware pins listed in the following table: Hardware Alarm Pins

Hardware Alarm Pins

Pin#	Symbol	Description	I/O	Logic	H	L	Pull-up/down
33	PRG_AL RM1	Programmable Alarm 1 MSA Default:HIPWR_ON	O	3.3V LVCMO S	Active High per MDIO document		
34	PRG_AL RM2	Programmable Alarm 2 MSA default:MOD_READY, Ready State has been reached	O	3.3V LVCMO S			
35	PRG_AL RM3	Programmable Alarm 3 MSA Default:	O	3.3V LVCMO S			

		MOD_FAULT					
38	MOD_AB S	Module Absent	O	3.3V LVCMOS	Absent	Present	Pull-Down Note1
40	RX_LOS	Receiver Loss of Signal	O	3.3V LVCMOS	Loss of Signal	OK	

Note1: Pull-Down resistor (<1000Ohm) is located within the CFP module. Pull-up should be located on the host

Management Interface Pins(MDIO)

The CFP Module supports alarm, control and monitor functions via an MDIO bus. The CFP MDIO pins are listed in the following table: Management Interface Pins

Management Interface Pins

Pin#	Symbol	Description	I/O	Logic	H	L	Pull-up/down
41	GLB_ALRMn	Global Alarm	I	3.3V LVCMOS	Ok	Alarm	
47	MDIO	Management Data Input Output Bi-Directional Data	I/O	1.2V LVCMOS			
48	MDC	MDIO Clock	I	1.2V LVCMOS			
46	PRTADR0	MDIO Physical Port address bit0	I	1.2V LVCMOS	per MDIO document[5]		
45	PRTADR1	MDIO Physical Port address bit1	I	1.2V LVCMOS			
44	PRTADR2	MDIO Physical Port address bit2	I	1.2V LVCMOS			
43	PRTADR3	MDIO Physical Port address bit3	I	1.2V LVCMOS			
42	PRTADR4	MDIO Physical Port address bit4	I	1.2V LVCMOS			

Hardware Signaling Pin Timing Requirements

Timing Parameters for CFP hardware Signal Pins are listed in the following table.

Timing Parameters for CFP hardware Signal Pins

Parameter	Symbol	Min	Max	Unit	Notes&Conditions
Hardware MOD_LOPWR assert	t_MOD_LOPWR_assert		1	ms	Application Specific May depend on current state Condition when signal is applied .See Vendor Datasheet
Hardware MOD_LOPWR deassert	t_MOD_LOPWR_deassert			ms	Value is dependent upon module start-up time.Please See register"Maximum High-Power-up ime" in "CFP MSA Management Interface Specification"
Receiver Loss of Signal Assert Time	t_loss_assert		100	us	Maximum value designed to support telecom applications
Receiver Loss of Signal De-Assert Time	t_loss_deassert		100	us	Maximum value designed to support telecom applications

Global Alarm Assert Delay Time	GLB_ALRMn_assert		150	ms	This is a logical “OR” of Associated MDIO alarm& status registers.Please see MDIO document for further details
Global Alarm De-assert Delay Time	GLB_ALRMn_deassert		150	ms	This is a logical “OR” of Associated MDIO alarm& status registers.Please see MDIO document for further details
Management Interface Clock Period	t_prd		250	ns	MDC is 4MHz rate
Host MDIO t_setup	t_setup		10	ns	
Host MDIO t_hold	t_hold		10	ns	
CFP MDIO t_delay	t_delay		0	175 ns	
Initialization time from Reset	t_initialize		2.5	s	
Transmitter Disabled(TX_DIS_asserted)	t_deassert		100	us	Application Specific
Transmitter Enabled(TX_DIS_asserted)	t_assert		100	ms	Value is dependent upon module start-up time.Please See register “Maximum TX-Turn-on Time” in “CFP MSA Management Interface Specification”

High Speed Electrical Characteristics

Reference Clock Characteristics

		Min	Typ	Max	Unit	Notes
Impedance	Zd	80	100	120	Ω	
Frequency			161.1328125		MHz	1/64 of electrical lane rate
Frequency Stability	Δf	-100		100	ppm	For Ethernet applications
		-20		20		For Telecom applications
Output Differential Voltage	V _{DIFF}	400		1200	mV	Peak to Peak Differential
RMS jitter ^{1,2}	σ			10	ps	Random Jitter Over frequency band of 10KHz<f<10MHz
Clock Duty Cycle		40		60	%	
Clock Rise/Fall Time 10%/90%	t _{r/f}	200		1250	ps	1/64 of electrical lane rate
		50		315		1/16 of electrical lane rate

Note1: The term “40GBASE_FR” is the 40GbE serial optical interface in the task force phase at IEEE-SA at the time of this publication. Also, 1/16 of optical lane clock is recommended for TX_MCLK and RX_MCLK

Note2: Multi-protocol modules are recommended to adopt the clock rate rate used in Telecom applications

Optional Transmitter and Receiver Monitor Clock Characteristics

		Min	Typ	Max	Unit	Notes
Impedance	Zd	80	100	120	Ω	
Frequency					MHz	1/8 of Network lane rate
Output	V _{DIFF}	400		1200	mV	Peak to Peak Differential

Differential Voltage						
Clock Duty Cycle		40		60	%	

CFP Register Allocation

CFP Register Allocation					
Starting Address in Hex	Ending Address in Hex	Access Type	Allocated Size	Data Bit Width	Table Name and Description
0000	7FFF	N/A	32768	N/A	Reserved for IEEE 802.3 use
8000	807F	RO	128	8	CFP NVR 1. Basic ID register
8080	80FF	RO	128	8	CFP NVR 2. Extended ID register
8100	817F	RO	128	8	CFP NVR 3. Network lane specific registers
8180	81FF	RO	128	8	CFP NVR 4
8200	83FF	RO	4x128	N/A	MSA Reserved
8400	847F	RO	128	8	Vendor NVR 1. Vendor data registers
8480	84FF	RO	128	8	Vendor NVR 2. Vendor data registers
8500	87FF	RO	6x128	N/A	Reserved by CFP MSA
8800	887F	R/W	128	8	User NVR 1. User data registers
8880	88FF	R/W	128	8	User NVR 2. User data registers
8900	8EFF	RO	12x128	N/A	Reserved by CFP MSA
8F00	8FFF	N/A	2x128	N/A	Reserved for User private use
9000	9FFF	RO	4096	N/A	Reserved for vendor private use
A000	A07F	R/W	128	16	CFP Module VR1. CFP Module level control and DDM registers
A080	A0FF	RO	128	16	Reserved by CFP MSA
A100	A1FF	RO	2x128	N/A	Reserved by CFP MSA
A200	A27F	R/W	128	16	Network Lane VR 1. Network lane specific register
A280	A2FF	R/W	128	16	Network Lane VR 2. Network lane specific register
A300	A3FF	RO	2x128	N/A	Reserved by CFP MSA
A400	A47F	R/W	128	16	Host lane VR1. Host lane specific registers
A480	AFFF	RO	23x128	N/A	Reserved by CFP MSA
B000	FFFF	RO	5x4096	N/A	Reserved by CFP MSA

CFP NVR1

CFP NVR1

Hex Addr	Size	Access Type	Bit	Register Name	Content (HEX)	LSB Unit
Base ID Information						
8000	1	RO	7~0	Module Identifier	0E	N/A
8001				Extended Identifier		
8002	1	RO	7~0	Connector Type Code		
8003	1	RO	7~0	Ethernet Application Code		
8004	1	RO	7~0	Fiber Channel Application Code		

8005	1	RO	7~0	Copper Link Application Code		
8006	1	RO	7~0	SONET/SDH Application Code		
8007	1	RO	7~0	OTN Application Code		
8008	1	RO	7~0	Additional Capable Rates Supported		
8009	1	RO	7~0	Number of Lanes Supported		
800A	1	RO	7~0	Media Properties		
800B	1	RO	7~0	Maximum Network Lane Bit Rate		
800C	1	RO	7~0	Maximum host Lane Bit Rate		
800D	1	RO	7~0	Maximum Single Mode Optical Fiber Length		
800E	1	RO	7~0	Maximum Multi-Mode Mode Optical Fiber Length		
800F	1	RO	7~0	Maximum Copper Cable length		
8010	1	RO	7~0	Transmitter Spectral Characteristics1		
8011	1	RO	7~0	Transmitter Spectral Characteristics2		
8012	2	RO	7~0	Minimum Wavelength per Active Fiber		
8014	2	RO	7~0	Maximum Wavelength per Active Fibe		
8016	2	RO	7~0	Maximum per Lane Optical Width		
8018	1	RO	7~0	Device Technology1		
8019	1	RO	7~0	Device Technology2		
801A	1	RO	7~0	Signal Code		
801B	1	RO	7~0	Maximum Total Optical Output Power per Connector		
801C	1	RO	7~0	Maximum Optical Input Power per Network Lane		
801D	1	RO	7~0	Maximum Power Consumption		
801E	1	RO	7~0	Maximum Power Consumption in Low Power Mode		
801F	1	RO	7~0	Maximum Operating Case Temp Range		
8020	1	RO	7~0	Minimum Operating Case Temp Range		
8021	16	RO	7~0	Vendor Name		
8031	3	RO	7~0	Vendor OUI		
8034	16	RO	7~0	Vendor Part Number		
8044	16	RO	7~0	Vendor Serial Number		
8054	8	RO	7~0	Data Code		
805C	2	RO	7~0	Lot Code		
805E	10	RO	7~0	CLEI Code		
8068	1	RO	7~0	CFP MSA hardware Specification Revision		

				Number		
8069	1	RO	7~0	CFP MSA Management Interface Specification Revision Number		
806A	2	RO	7~0	Module Hardware Version Number		
806C	2	RO	7~0	Module Firmware Version Number		
806E	1	RO	7~0	Digital Diagnostic Monitoring Type		
806F	1	RO	7~0	Digital Diagnostic Monitoring Capability 1		
8070	1	RO	7~0	Digital Diagnostic Monitoring Capability 2		
8071	1	RO	7~0	Module Enhanced Options		
8072	1	RO	7~0	Maximum High-Power-up Time		
8073	1	RO	7~0	Maximum TX-Turn-on Time		
8074	1	RO	7~0	Host Lane Signal Spec		
8075	1	RO	7~0	Heat Sink Type		
8076	1	RO	7~0	Maximum TX-Turn-off Time		
8077	1	RO	7~0	Maximum High-Power-down Time		
8078	1	RO	7~0	Module Enhanced Options 2		
8079	1	RO	7~0	Transmitter Monitor Clock Options		
807A	1	RO	7~0	Receiver Monitor Clock Options		
807B	4	RO		Reserved		
807F	1	RO	7~0	CFP NVR 1 Checksum		

CFP NVR2

Alarm/Warning Threshold Registers

Hex Addr	Size	Access Type	Bit	Register Name	Content (HEX)	LSB Unit
Base ID Information						
8080	2	RO	7~0	Transceiver Temp High Alarm Threshold		
8082	2	RO	7~0	Transceiver Temp High Warning Threshold		
8084	2	RO	7~0	Transceiver Temp Low Warning Threshold		
8086	2	RO	7~0	Transceiver Temp Low Alarm Threshold		
8088	2	RO	7~0	VCC High Alarm Threshold		
808A	2	RO	7~0	VCC High Warning Threshold		
808C	2	RO	7~0	VCC Low Warning Threshold		
808E	2	RO	7~0	VCC Low Alarm Threshold		
8090	2	RO	7~0	SOA Bias Current High Alarm Threshold		
8092	2	RO	7~0	SOA Bias Current High Warning Threshold		
8094	2	RO	7~0	SOA Bias Current Low Warning Threshold		
8096	2	RO	7~0	SOA Bias Current Low Alarm Threshold		
8098	2	RO	7~0	Auxiliary 1 Monitor High Alarm Threshold		
809A	2	RO	7~0	Auxiliary 1 Monitor High Warning Threshold		
809C	2	RO	7~0	Auxiliary 1 Monitor Low Warning Threshold		
809E	2	RO	7~0	Auxiliary 1 Monitor Low Alarm Threshold		

80A0	2	RO	7~0	Auxiliary 2 Monitor High Alarm Threshold		
80A2	2	RO	7~0	Auxiliary 2 Monitor High Warning Threshold		
80A4	2	RO	7~0	Auxiliary 2 Monitor Low Warning Threshold		
80A6	2	RO	7~0	Auxiliary 2 Monitor Low Alarm Threshold		
80A8	2	RO	7~0	Laser Bias Current High Alarm Threshold		
80AA	2	RO	7~0	Laser Bias Current High Warning Threshold		
80AC	2	RO	7~0	Laser Bias Current Low Warning Threshold		
80AE	2	RO	7~0	Laser Bias Current Low Alarm Threshold		
80B0	2	RO	7~0	Laser Output Power High Alarm Threshold		
80B2	2	RO	7~0	Laser Output Power High Warning Threshold		
80B4	2	RO	7~0	Laser Output Power Low Warning Threshold		
80B6	2	RO	7~0	Laser Output Power Low Alarm Threshold		
80B8	2	RO	7~0	Laser Temperature High Alarm Threshold		
80BA	2	RO	7~0	Laser Temperature High Warning Threshold		
80BC	2	RO	7~0	Laser Temperature Low Warning Threshold		
80BE	2	RO	7~0	Laser Temperature Low Alarm Threshold		
80C0	2	RO	7~0	Receive Optical Power High Alarm Threshold		
80C2	2	RO	7~0	Receive Optical Power High Warning Threshold		
80C4	2	RO	7~0	Receive Optical Power Low Warning Threshold		
80C6	2	RO	7~0	Receive Optical Power Low Alarm Threshold		
80C8	55	RO	7~0	Reserved		
80FF	1	RO	7~0	CFP NVR 2 Checksum		

CFP NVR3

Network Lane BOL Measurement Registers

Hex Addr	Size	Access Type	Bit	Register Name	Content (HEX)	LSB Unit
Base ID Information						
8100	32	RO	7~0	Rx Sensitivity Spec for network lanes 0~15		
8120	32	RO	7~0	Tx Power Spec for network lanes 0~15		
8140	32	RO	7~0	Measured ER for network lanes 0~15		
8160	32	RO	7~0	Path Penalty for network lanes 0~15		

CFP NVR4

Hex Addr	Size	Access Type	Bit	Register Name	Content (HEX)	LSB Unit
Base ID Information						
8180	1	RO	7~0	CFP NVR3 Checksum		
8181	127	RO	7~1	Reserved		

CFP VR1

Hex Addr	Size	Access Type	Bit	Register Name	Content (HEX)	LSB Unit
Module Command/Setup Registers						
A000	2	RO	15~0	Reserved		
A002	2	RO	15~0	Reserved		
A004	1	RO		NVR Access Control		
			8~6	Reserved		

			4	Reserved		
			3~2	Command Status		
		RW	15~9	Reserved		
			5	User Restore and Save Command		
			1~0	Extended Commands		
A005	1	RO		PRG_CNTL3 Function Select		
			15~8	Reserved		
		RW	7~0	Function Select Code		
A006	1	RO		PRG_CNTL2 Function Select		
			15~8	Reserved		
		RW	7~0	Function Select Code		
A007	1	RO		PRG_CNTL1 Function Select		
			15~8	Reserved		
		RW	7~0	Function Select Code		
A008	1	RO		PRG_ALRM3 Source Select		
			15~8	Reserved		
		RW	7~0	Alarm Source Code		
A009	1	RO		PRG_ALRM2 Source Select		
			15~8	Reserved		
		RW	7~0	Alarm Source Code		
A00A	1	RO		PRG_ALRM1 Source Select		
			15~8	Reserved		
		RW	7~0	Alarm Source Code		
A00B	1	RO		Module Bi-/Uni-Directional Operating Mode Select		
			15~3	Reserved		
		RW	2~0	Module Bi/uni-Direction Mode Select		
A00C	4	RO		Reserved		
Module Control Registers						
A010	1			Module General Control		
		RW/SC/LH	15	Soft Module Reset		
		RW	14	Soft Module Low Power		
		RW	13	Soft TX Disable		
		RW	12	Soft PRG_CNTL3 Control		
		RW	11	Soft PRG_CNTL2 Control		
		RW	10	Soft PRG_CNTL1 Control		
		RW	9	Soft GLB_ALRM Test		
		RO	8~6	Reserved		
		RO	5	TX_DIS Pin State		
		RO	4	MOD_LOPWR Pin State		
		RO	3	PRG_CNTL3 Pin State		
		RO	2	PRG_CNTL2 Pin State		
		RO	1	PRG_CNTL1 Pin State		
		RO	0	Reserved		
A011	1			Network Lane TX Control		
		RO	15	Reserved		
		RW	14	TX PRBS Generator Enable		
		RW	13	TX PRBS Pattern 1		
		RW	12	TX PRBS Pattern 0		
		RW	11	TX De-skew Enable		

		RW	10	TX FIFO Reset		
		RW	9	TX FIFO Auto Reset		
		RW	8	TX Reset		
		RW	7~5	TX MCLK Control		
		RO	4	Reserved		
		RW	3~1	TX Rate Select (10G lane rate)		
		RW	0	TX Reference CLK Rate Select		
A012	1			Network Lane RXControl		
		RW	15	Active Decision Voltageand Phase function		
		RW	14	RX PRBS CheckerEnable		
		RW	13	RX PRBS Pattern 1		
		RW	12	RX PRBS Pattern 0		
		RW	11	RX Lock RX_MCLK to Reference CLK		
		RW	10	Network Lane Loop-back		
		RW	9	RX FIFO Auto Reset		
		RW	8	RX Reset		
		RW	7~5	RX MCLK Control		
		RW	4	RX FIFO Reset		
		RW	3~1	RX Rate Select		
RW	0	RX Reference CLK Rate Select				
A013	1	RW		Individual Network Lane TX_DIS Control		
			15	Lane 15 Disable		
			14	Lane 14 Disable		
			13	Lane 13 Disable		
			12	Lane 12 Disable		
			11	Lane 11 Disable		
			10	Lane 10 Disable		
			9	Lane 9 Disable		
			8	Lane 8 Disable		
			7	Lane 7 Disable		
			6	Lane 6 Disable		
			5	Lane 5 Disable		
			4	Lane 4 Disable		
			3	Lane 3 Disable		
	2	Lane 2 Disable				
	1	Lane 1 Disable				
	0	Lane 0 Disable				
A014	1			Host Lane Control		
		RO	15	Reserved		
		RW	14	TX PRBS Checker Enable		
		RW	13	TX PRBS Pattern 1		
		RW	12	TX PRBS Pattern 0		
		RO	11	Reserved		
		RW	10	Host Lane Loop-back Enable		
		RO	9	Reserved		
		RO	8	Reserved		
		RW	7	RX PRBS Generator Enable		
RW	6	RX PRBS Pattern 1				

		RW	5	RX PRBS Pattern 0		
		RO	4~0	Reserved		
A015	1	RO		Reserved		
A016	1	RO		Module State		
			15~9	Reserved		
			8	High-Power-down State		
			7	TX-Turn-off State		
			6	Fault State		
			5	Ready State		
			4	TX-Turn-on State		
			3	TX-Off State		
			2	High-Power-up State		
			1	Low-Power State		
			0	Initialize State		
A017	1	RO		Reserved		
A018	1	RO		Global Alarm Summary		
			15	GLB_ALRM Assertion Status		
			14	Host Lane Fault and Status Summary		
			13	Network Lane Fault and Status Summary		
			12	Network Lane Alarm and Warning Summary		
			11	Module Alarm and Warning 2 Summary		
			10	Module Alarm and Warning 1 Summary		
			9	Module Fault Summary		
			8	Module General Status Summary		
			7	Module State Summary		
			6~1	Reserved		
			0	Soft GLB_ALRM Test Status		
A019	1	RO		Network Lane Alarm and Warning Summary		
			15	Lane 15 Alarm and Warning Summary		
			14	Lane 14 Alarm and Warning Summary		
			13	Lane 13 Alarm and Warning Summary		
			12	Lane 12 Alarm and Warning Summary		
			11	Lane 11 Alarm and Warning Summary		
			10	Lane 10 Alarm and Warning Summary		
			9	Lane 9 Alarm and Warning Summary		
			8	Lane 8 Alarm and Warning Summary		
			7	Lane 7 Alarm and Warning Summary		

			6	Lane 6 Alarm and Warning Summary		
			5	Lane 5 Alarm and Warning Summary		
			4	Lane 4 Alarm and Warning Summary		
			3	Lane 3 Alarm and Warning Summary		
			2	Lane 2 Alarm and Warning Summary		
			1	Lane 1 Alarm and Warning Summary		
			0	Lane 0 Alarm and Warning Summary		
A01A	1	RO		Network Lane Fault and Status Summary		
			15	Lane 15 Fault and Status Summary		
			14	Lane 14 Fault and Status Summary		
			13	Lane 13 Fault and Status Summary		
			12	Lane 12 Fault and Status Summary		
			11	Lane 11 Fault and Status Summary		
			10	Lane 10 Fault and Status Summary		
			9	Lane 9 Fault and Status Summary		
			8	Lane 8 Fault and Status Summary		
			7	Lane 7 Fault and Status Summary		
			6	Lane 6 Fault and Status Summary		
			5	Lane 5 Fault and Status Summary		
			4	Lane 4 Fault and Status Summary		
			3	Lane 3 Fault and Status Summary		
			2	Lane 2 Fault and Status Summary		
			1	Lane 1 Fault and Status Summary		
			0	Lane 0 Fault and Status Summary		
A01B	1	RO		Host Lane Fault and Status Summary		
			15	Lane 15 Fault and Status Summary		
			14	Lane 14 Fault and Status Summary		
			13	Lane 13 Fault and Status Summary		
			12	Lane 12 Fault and Status Summary		
			11	Lane 11 Fault and Status Summary		
			10	Lane 10 Fault and Status Summary		
			9	Lane 9 Fault and Status Summary		
			8	Lane 8 Fault and Status Summary		
			7	Lane 7 Fault and Status Summary		
			6	Lane 6 Fault and Status Summary		
			5	Lane 5 Fault and Status Summary		
			4	Lane 4 Fault and Status Summary		
			3	Lane 3 Fault and Status Summary		
			2	Lane 2 Fault and Status Summary		
			1	Lane 1 Fault and Status Summary		
			0	Lane 0 Fault and Status Summary		
A01C	1	RO		Reserved		

Module FAWS Registers				
A01D	1	RO	Module General Status	
			15	Reserved
			14	Reserved
			13	HW_Interlock
			12~11	Reserved
			10	Loss of REFCLK Input
			9	TX_JITTER_PLL_LOL
			8	TX_CMU_LOL
			7	TX_LOSF
			6	TX_HOST_LOL
			5	RX_LOS
			4	RX_NETWORK_LOL
			3	Out of Alignment
			2	Reserved
			1	HIPWR_ON
0	Reserved			
A01E	1	RO	Module Fault Status	
			15	Reserved
			14~7	Reserved
			6	PLD or Flash Initialization Fault
			5	Power Supply Fault
			4~2	Reserved
			1	CFP Checksum Fault
0	Reserved			
A01F	1	RO	Module Alarms and Warnings 1	
			15~12	Reserved
			11	Mod Temp High Alarm
			10	Mod Temp High Warning
			9	Mod Temp Low Warning
			8	Mod Temp Low Alarm
			7	Mod Vcc High Alarm
			6	Mod Vcc High Warning
			5	Mod Vcc Low Warning
			4	Mod Vcc Low Alarm
			3	Mod SOA Bias High Alarm
			2	Mod SOA Bias High Warning
1	Mod SOA Bias Low Warning			
0	Mod SOA Bias Low Alarm			
A020	1	RO	Module Alarms and Warnings 2	
			15~8	Reserved
			7	Mod Aux 1 High Alarm
			6	Mod Aux 1 High Warning
			5	Mod Aux 1 Low Warning
			4	Mod Aux 1 Low Alarm
			3	Mod Aux 2 High Alarm
			2	Mod Aux 2 High Warning
			1	Mod Aux 2 Low Warning
0	Mod Aux 2 Low Alarm			
A021	1	RO	Reserved	
A022	1		Module State Latch	

		RO	15~9	Reserved		
		RO/LH/COR	8	High-Power-down State Latch		
		RO/LH/COR	7	TX-Turn-off State Latch		
		RO/LH/COR	6	Fault State Latch		
		RO/LH/COR	5	Ready State Latch		
		RO/LH/COR	4	TX-Turn-on State Latch		
		RO/LH/COR	3	TX-Off State Latch		
		RO/LH/COR	2	High-Power-up State Latch		
		RO/LH/COR	1	Low-Power State Latch		
		RO/LH/COR	0	Initialize State Latch		
A023	1			Module General Status Latch		
		RO	15	Reserved		
		RO	14	Reserved		
		RO/LH/COR	13	HW_Interlock Latch		
		RO	12~11	Reserved		
		RO/LH/COR	10	Loss of REFCLK Input Latch		
		RO/LH/COR	9	TX_JITTER_PLL_LOL Latch		
		RO/LH/COR	8	TX_CMU_LOL Latch		
		RO/LH/COR	7	TX_LOSF Latch		
		RO/LH/COR	6	TX_HOST_LOL Latch		
		RO/LH/COR	5	RX_LOS Latch		
		RO/LH/COR	4	RX_NETWORK_LOL Latch		
		RO/LH/COR	3	Out of Alignment Latch		
	RO	2~0	Reserved			
A024	1			Module Fault Status latch		
		RO	15~7	Reserved		
		RO/LH/COR	6	PLD or Flash Initialization Fault Latch		
		RO/LH/COR	5	Power Supply Fault Latch		
		RO	4~2	Reserved		
		RO/LH/COR	1	CFP Checksum Fault Latch		
	RO	0	Reserved			
A025	1			Module Alarms and Warnings 1 Latch		
		RO	15~12	Reserved		
		RO/LH/COR	11	Mod Temp High Alarm Latch		
		RO/LH/COR	10	Mod Temp High Warning Latch		
		RO/LH/COR	9	Mod Temp Low Warning Latch		
		RO/LH/COR	8	Mod Temp Low Alarm Latch		
		RO/LH/COR	7	Mod Vcc High Alarm Latch		
		RO/LH/COR	6	Mod Vcc High Warning Latch		
		RO/LH/COR	5	Mod Vcc Low Warning Latch		
RO/LH/COR	4	Mod Vcc Low Alarm Latch				

		RO/LH/C OR	3	Mod SOA Bias High Alarm Latch		
		RO/LH/C OR	2	Mod SOA Bias High Warning Latch		
		RO/LH/C OR	1	Mod SOA Bias Low Warning Latch		
		RO/LH/C OR	0	Mod SOA Bias Low Alarm Latch		
A026	1			Module Alarms and Warnings 2 latch		
		RO	15~8	Reserved		
		RO/LH/C OR	7	Mod Aux 1 High Alarm Latch		
		RO/LH/C OR	6	Mod Aux 1 High Warning Latch		
		RO/LH/C OR	5	Mod Aux 1 Low Warning Latch		
		RO/LH/C OR	4	Mod Aux 1 Low Alarm Latch		
		RO/LH/C OR	3	Mod Aux 2 High Alarm Latch		
		RO/LH/C OR	2	Mod Aux 2 High Warning Latch		
		RO/LH/C OR	1	Mod Aux 2 Low Warning Latch		
		RO/LH/C OR	0	Mod Aux 2 Low Alarm Latch		
A027	1	RO		Reserved		
A028	1			Module Stable Enable		
		RO	15~9	Reserved		
		RW	8	High-Power-down State Enable		
		RW	7	TX-Turn-off State Enable		
		RW	6	Fault State Enable		
		RW	5	Ready State Enable		
		RW	4	TX-Turn-on State Enable		
		RW	3	TX-Off State Enable		
		RW	2	High-Power-up State Enable		
		RW	1	Low-Power State Enable		
		RO	0	Initialize State Enable		
A029	1			Module General Status Enable		
		RW	15	GLB_ALRM Master Enable		
		RO	14	Reserved		
		RW	13	HW Interlock		
		RO	12~11	Reserved		
		RW	10	Loss of REFCLK Input Enable		
		RW	9	TX_JITTER_PLL_LOL Enable		
		RW	8	TX_CMU_LOL Enable		
		RW	7	TX_LOSF Enable		
		RW	6	TX_HOST_LOL Enable		
		RW	5	RX_LOS Enable		
		RW	4	RX_NETWORK_LOL Enable		
		RW	3	Out of Alignment Enable		

		RO	2~0	Reserved		
A02A	1			Module Fault Status Enable		
		RO	15~7	Reserved		
		RW	6	PLD or Flash Initialization Fault Enable		
		RW	5	Power Supply Fault Enable		
		RO	4~2	Reserved		
		RW	1	CFP Checksum Fault Enable		
		RO	0	Reserved		
A02B	1	RO		Module Alarm and Warnings 1 Enable		
			15~12	Reserved		
			11	Mod Temp Hi Alarm Enable		
			10	Mod Temp Hi Warn Enable		
			9	Mod Temp Low Warning Enable		
			8	Mod Temp Low Alarm Enable		
			7	Mod Vcc High Alarm Enable		
			6	Mod Vcc High Warning Enable		
			5	Mod Vcc Low Warning Enable		
			4	Mod Vcc Low Alarm Enable		
			3	Mod SOA Bias High Alarm Enable		
			2	Mod SOA Bias High Warning Enable		
			1	Mod SOA Bias Low Warning Enable		
0	Mod SOA Bias Low Alarm Enable					
A02C	1			Module Alarms and Warnings Enable		
		RO	15~8	Reserved		
		RW	7	Mod Aux 1 High Alarm Enable		
			6	Mod Aux 1 High Warning Enable		
			5	Mod Aux 1 Low Warning Enable		
			4	Mod Aux 1 Low Alarm Enable		
			3	Mod Aux 2 High Alarm Enable		
			2	Mod Aux 2 High Warning Enable		
			1	Mod Aux 2 Low Warning Enable		
0	Mod Aux 2 Low Alarm Enable					
A02D	2	RO		Reserved		
Module Analog A/D Value Registers						
A02F	1	RO	15~0	Module Temp Monitor A/D Value		
A030	1	RO	15~0	Module Power supply 3.3 V Monitor A/D Value		
A031	1	RO	15~0	SOA Bias Current A/D Value		
A032	1	RO	15~0	Module Auxiliary 1 Monitor A/D Value		
A033	1	RO	15~0	Module Auxiliary 2 Monitor A/D Value		
A034	4	RO		Reserved		
Module PRBS Registers						
A038	1	RO		Network Lane PRBS Data Bit		

				Count		
			15~10	Exponent		
			9~0	Mantissa		
A039	1	RO		Host Lane PRBS Data Bit Count		
			15~10	Exponent		
			9~0	Mantissa		
A03A	70	RO		Reserved		

CFP Network Lane VR1

Network Lane VR1

Network Lane VR1						
Hex Addr	Size	Access Type	Bit	Register Name	Content (HEX)	LSB Unit
Network Lane FAWS Registers						
A200	16	RO		Network Lane n Alarm and Warning		
			15	Bias High Alarm		
			14	Bias High Warning		
			13	Bias Low Warning		
			12	Bias Low Alarm		
			11	TX Power High Alarm		
			10	TX Power High Warning		
			9	TX Power Low Warning		
			8	TX Power Low Alarm		
			7	Laser Temperature High Alarm		
			6	Laser Temperature High Warning		
			5	Laser Temperature Low Warning		
			4	Laser Temperature Low Alarm		
			3	RX Power High Alarm		
			2	RX Power High Warning		
			1	RX Power Low Warning		
			0	RX Power Low Alarm		
A210	16	RO		Network Lane n Fault and Status		
			15	Lane TEC Fault		
			14	Lane Wavelength Unlocked Fault		
			13	Lane APD Power Supply Fault		
			12~8	Reserved		
			7	Lane TX_LOSF		
			6	Lane TX_LOL		
			5	Reserved		
			4	Lane RX_LOS		
			3	Lane RX_LOL		
			2	Lane RX FIFO error		
			1	Reserved		
			0	Reserved		
Network Lane FAWS Latch Registers						
A220	16	RO/LH/COR		Network Lane n Alarm and Warning Latch		
			15	Bias High Alarm Latch		
			14	Bias High Warning Latch		
			13	Bias Low Warning Latch		

			12	Bias Low Alarm Latch		
			11	TX Power High Alarm Latch		
			10	TX Power High Warning Latch		
			9	TX Power Low Warning Latch		
			8	TX Power Low Alarm Latch		
			7	Laser Temperature High Alarm Latch		
			6	Laser Temperature High Warning Latch		
			5	Laser Temperature Low Warning Latch		
			4	Laser Temperature Low Alarm Latch		
			3	RX Power High Alarm Latch		
			2	RX Power High Warning Latch		
			1	RX Power Low Warning Latch		
			0	RX Power Low Alarm Latch		
A230	16	RO/LH/CO R		Network Lane n Fault and Status latch		
			15	Lane TEC Fault Latch		
			14	Lane Wavelength Unlocked Fault Latch		
			13	Lane APD Power Supply Fault Latch		
			12~8	Reserved		
			7	Lane TX_LOSF Latch		
			6	Lane TX_LOL Latch		
			5	Reserved		
			4	Lane RX_LOS Latch		
			3	Lane RX_LOL Latch		
			2	Lane RX FIFO Status Latch		
		RO	1~0	Reserved		
A240	16	RW		Network Lane n Alarm and Warning Enable		
			15	Bias High Alarm Enable		
			14	Bias High Warning Enable		
			13	Bias Low Warning Enable		
			12	Bias Low Alarm Enable		
			11	TX Power High Alarm Enable		
			10	TX Power High Warning Enable		
			9	TX Power Low Warning Enable		
			8	TX Power Low Alarm Enable		
			7	Laser Temperature High Alarm Enable		
			6	Laser Temperature High Warning Enable		
			5	Laser Temperature Low Warning Enable		
			4	Laser Temperature Low Alarm Enable		
			3	RX Power High Alarm Enable		
			2	RX Power High Warning Enable		
			1	RX Power Low Warning Enable		
			0	RX Power Low Alarm Enable		
A250	16			Network Lane n Fault and Status Enable		
		RW	15	Lane TEC Fault Enable		
		RW	14	Lane Wavelength Unlocked Fault Enable		
		RW	13	Lane APD Power Supply Fault Enable		
		RO	12~8	Reserved		
		RW	7	Lane TX_LOSF Enable		

		RW	6	Lane TX_LOL Enable		
		RO	5	Reserved		
		RW	4	Lane RX_LOS Enable		
		RW	3	Lane RX_LOL Enable		
		RW	2	Lane RX_FIFO Status Enable		
		RO	1~0	Reserved		
A260	32	RO		Reserved		

CFP Network Lane VR2

Network Lane VR2

Network Lane VR1						
Hex Addr	Size	Access Type	Bit	Register Name	Content (HEX)	LSB Unit
Network Lane Control Registers						
A280	16			Network Lane n FEC Controls		
		RW	15~8	Phase Adjustment		
		RW	7~0	Amplitude Adjustment		
A290	16	RO	15~0	Network Lane n PRBS Rx Error Count		
			15~10	Exponent		
			9~0	Mantissa		
Network Lane A/D value Measurement Registers						
A2A0	16	RO	15~0	Network Lane n Laser Bias Current monitor A/D value		
A2B0	16	RO	15~0	Network Lane n Laser Output Power monitor A/D value		
A2C0	16	RO	15~0	Network Lane n Laser Temp Monitor A/D value		
A2D0	16	RO	15~0	Network Lane n Receiver Input Power monitor A/D value		
A2E0	32	RO	15~0	Reserved		

CFP Host lane Lane VR1

Host Lane VR1

Host Lane VR1						
Hex Addr	Size	Access Type	Bit	Register Name	Content (HEX)	LSB Unit
Host Lane FAWS Status Registers						
A400	16			Host Lane m Fault and Status		
		RO	15~2	Reserved		
		RO	1	Lane TX_FIFO Error		
		RO	0	TX_HOST_LOL		
Host Lane FAWS Latch Registers						
A410	16			Host Lane m Fault and Status Latch		
		RO	15~2	Reserved		
		RO/LH/CO R	1	Lane TX_FIFO Error Latch		
		RO/LH/CO R	0	TX_HOST_LOL Latch		
Host Lane FAWS Enable Registers						
A420	16			Host Lane m Fault and Status		

				Enable		
		RO	15~2	Reserved		
		RW	1	Lane TX FIFO Error Enable		
		RW	0	TX_HOST_LOL_Enable		
Host Lane Digital PRBS Register						
A430	16			Host Lane m PRBS TX Error Count		
		RO	15~10	Exponent		
		RW	9~0	Mantissa		
Host Lane Control Registers						
A440	16			Host Lane m Control		
		RO	15~4	Reserved		
		RW	3~0	Signal Pre/De-emphasis		
A450	48	RO		Reserved		

Pin Description

The CFP connector has 148 pins which are arranged in Top and Bottom rows. The pin map is shown in Table below. The detailed description of the Bottom row ranges from pin 1 through pin 74 and is shown Table 5-7 in below. The pin orientation is shown below in Figure 5-18.

Figure : CFP Pin Map Orientation

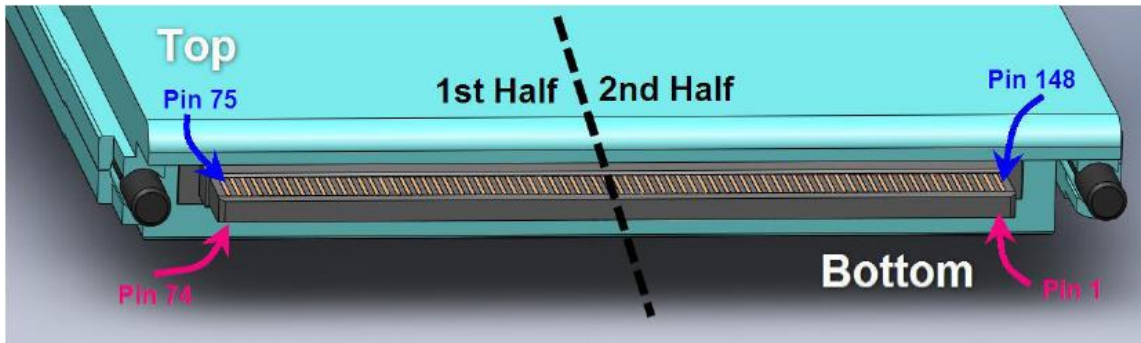

Table : CFP Pin-Map

PIN#	Top Row (2nd Half) Name	PIN#	Bottom Row (2nd Half) Name	PIN#	Top Row (1st Half) Name	PIN#	Bottom Row (1st Half) Name
148	GND	1	3.3V_GND	111	GND	38	MOD_ABS
147	REFCLKn	2	3.3V_GND	110	N.C	39	MOD_RSTn

146	REFCLKp	3	3.3V_GND	109	N.C	40	RX_LOS
145	GND	4	3.3V_GND	108	GND	41	GLB_ALRMn
144	N.C.	5	3.3V_GND	107	RX9n	42	PRTADR4
143	N.C.	6	3.3V	106	RX9p	43	PRTADR3
142	GND	7	3.3V	105	GND	44	PRTADR2
141	TX9n	8	3.3V	104	RX8n	45	PRTADR1
140	TX9n	9	3.3V	103	RX8p	46	PRTADR0
139	GND	10	3.3V	102	GND	47	MDIO
138	TX8n	11	3.3V	101	RX7n	48	MDC
137	TX8p	12	3.3V	100	RX7p	49	GND
136	GND	13	3.3V	99	GND	50	VND_IO_F
135	TX7n	14	3.3V	98	RX6n	51	VND_IO_G
134	TX7p	15	3.3V	97	RX6p	52	GND
133	GND	16	3.3V_GND	96	GND	53	VND_IO_H
132	TX6n	17	3.3V_GND	95	RX5n	54	VND_IO_J
131	TX6p	18	3.3V_GND	94	RX5p	55	3.3V_GND
130	GND	19	3.3V_GND	93	GND	56	3.3V_GND
129	TX5n	20	3.3V_GND	92	RX4n	57	3.3V_GND
128	TX5p	21	VND_IO_A	91	RX4p	58	3.3V_GND
127	GND	22	VND_IO_B	90	GND	59	3.3V_GND
126	TX4n	23	GND	89	RX3n	60	3.3V
125	TX4p	24	TX_MCLKn	88	RX3p	61	3.3V
124	GND	25	TX_MCLKp	87	GND	62	3.3V
123	TX3n	26	GND	86	RX2n	63	3.3V
122	TX3p	27	VND_IO_C	85	RX2p	64	3.3V
121	GND	28	VND_IO_D	84	GND	65	3.3V
120	TX2n	29	VND_IO_E	83	RX1n	66	3.3V
119	TX2p	30	PRG_CNTL1	82	RX1p	67	3.3V
118	GND	31	PRG_CNTL2	81	GND	68	3.3V
117	TX1n	32	PRG_CNTL3	80	RX0n	69	3.3V
116	TX1p	33	PRG_ALRM1	79	RX0p	70	3.3V_GND
115	GND	34	PRG_ALRM2	78	GND	71	3.3V_GND
114	TX0n	35	PRG_ALRM3	77	RX_MCLKn	72	3.3V_GND
113	TX0p	36	TX_DIS	76	RX_MCLKp	73	3.3V_GND

112	GND	37	MOD_LOPWR	75	GND	74	3.3V_GND
-----	-----	----	-----------	----	-----	----	----------

Table: Pin description

PIN#	Name	I/O	Logic	Description
1	3.3V_GND			3.3V Module Supply Voltage Return Ground, can be separate or tied together with Signal
2	3.3V_GND			
3	3.3V_GND			
4	3.3V_GND			
5	3.3V_GND			
6	3.3V			3.3V Module Supply Voltage
7	3.3V			
8	3.3V			
9	3.3V			
10	3.3V			
11	3.3V			
12	3.3V			
13	3.3V			
14	3.3V			
15	3.3V			
16	3.3V_GND			3.3V Module Supply Voltage Return Ground, can be separate or tied together with Signal
17	3.3V_GND			
18	3.3V_GND			
19	3.3V_GND			
20	3.3V_GND			
21	VND_IO_A	I/O		Module Vendor I/O. Do Not Connect
22	VND_IO_B	I/O		Module Vendor I/O. Do Not Connect
23	GND			
24	TX_MCLKn	O	CML	For optical waveform testing. Not for normal use
25	TX_MCLKp	O	CML	For optical waveform testing. Not for normal use

26	GND			
27	VND_IO_C	I/O		Module Vendor I/O C. Do Not Connect
28	VND_IO_D	I/O		Module Vendor I/O C. Do Not Connect
29	VND_IO_E	I/O		Module Vendor I/O C. Do Not Connect
30	PRG_CNTL1	I	LVC MOS w/PUR	Programmable Control 1 set over MDIO. MSA Default: TRXIC_RSTn, TX&RX ICs reset,"0" Reset, "1" or NC: enabled=not used
31	PRG_CNTL2	I	LVC MOS w/PUR	Programmable Control 2 set over MDIO. MSA Default: Hardware Interlock LSB, "00"≤8W, "01" ≤16W, "10" ≤24W, "11" or NC≤24W=not used
32	PRG_CNTL3	I	LVC MOS w/PUR	Programmable Control 2 set over MDIO. MSA Default: Hardware Interlock MSB, "00"≤8W, "01" ≤16W, "10" ≤24W, "11" or NC≤24W=not used
33	PRG_ALARM1	O	LVC MOS	Programmable Alarm 1 set over MDIO, MSA Default: HIPWR_ON."1":module power up completed,"0": module not high powered up
34	PRG_ALARM2	O	LVC MOS	Programmable Alarm 2 set over MDIO, MSA Default: MOD_READY, "1": Ready, "0": not Ready
35	PRG_ALARM3	O	LVC MOS	Programmable Alarm 3 set over MDIO, MSA Default: MOD_FAULT, fault detected, "1": Fault, "0": No Fault
36	TX_DIS	I	LVC MOS w/PUR	Transmitter Disable for all lanes, "1" or NC=transmitter disabled,"0"=transmitter enabled
37	MOD_LOPWR	I	LVC MOS w/PUR	Module Low Power Mode."1" or NC: module in low power(safe) mode, "0": power-on enabled
38	MOD_ABS	O	GND	Module Absent "1" or "NC": module absent, "0": module present, Pull Up Resistor in Module
39	MOD_RSTn	I	LVC MOS w/PDR	Module Reset. "0" reset the module, "1" or NC=module enabled, Pull Down Resistor in Module
40	RX_LOS	O	LVC MOS	Receiver Loss of Optical Signal, "1": low optical signal, "0": normal condition
41	GLB_ALRMn	O	LVC MOS	Global Alarm, "0" :alarm condition in any MDIO Alarm register, "1": no alarm condition, Open Drain, Pull up Resistor on Host
42	PRTADR4	I	1.2V CMOS	MDIO Physical Port address bit4

43	PRTADR3	I	1.2V CMOS	MDIO Physical Port address bit3
44	PRTADR2	I	1.2V CMOS	MDIO Physical Port address bit2
45	PRTADR1	I	1.2V CMOS	MDIO Physical Port address bit1
46	PRTADR0	I	1.2V CMOS	MDIO Physical Port address bit0
47	MDIO	I/O	1.2V CMOS	Management Data I/O bi-directional data (electrical specs as per 802.3ae and ba)
48	MDC	I	1.2V CMOS	Management Data Clock(Electrical specs as per 802.3ae and ba)
49	GND			
50	VND_IO_F	I/O		Module Vendor I/O F. Do Not Connect
51	VND_IO_G	I/O		Module Vendor I/O G. Do Not Connect
52	GND			
53	VND_IO_H	I/O		Module Vendor I/O H. Do Not Connect
54	VND_IO_J	I/O		Module Vendor I/O J. Do Not Connect
55	3.3V_GND			3.3V Module Supply Voltage Return Ground, can be separate or tied together with Signal
56	3.3V_GND			
57	3.3V_GND			
58	3.3V_GND			
59	3.3V_GND			
60	3.3V			3.3V Module Supply Voltage
61	3.3V			
62	3.3V			
63	3.3V			
64	3.3V			
65	3.3V			
66	3.3V			
67	3.3V			
68	3.3V			
69	3.3V			
70	3.3V_GND			3.3V Module Supply Voltage Return Ground, can be separate or tied together with Signal
71	3.3V_GND			
72	3.3V_GND			
73	3.3V_GND			

74	3.3V_GND			
75	GND			
76	RX_MCLKp	O	CML	Receiver Monitor Clock (Optional)
77	RX_MCLKn	O	CML	Receiver Monitor Inverted Clock (Optional)
78	GND			
79	RX0p	O	CML	Output Data
80	RX0n	O	CML	Inverted Output Data
81	GND			
82	RX1p	O	CML	Output Data
83	RX1n	O	CML	Inverted Output Data
84	GND			
85	RX2p	O	CML	Output Data
86	RX2n	O	CML	Inverted Output Data
87	GND			
88	RX3p	O	CML	Output Data
89	RX3n	O	CML	Inverted Output Data
90	GND			
91	RX4p	O	CML	Output Data
92	RX4n	O	CML	Inverted Output Data
93	GND			
94	RX5p	O	CML	Output Data
95	RX5n	O	CML	Inverted Output Data
96	GND			
97	RX6p	O	CML	Output Data
98	RX6n	O	CML	Inverted Output Data
99	GND			
100	RX7p	O	CML	Output Data
101	RX7n	O	CML	Inverted Output Data
102	GND			
103	RX8p	O	CML	Output Data
104	RX8n	O	CML	Inverted Output Data
105	GND			
106	RX9p	O	CML	Output Data
107	RX9n	O	CML	Inverted Output Data

108	GND			
109	N.C			
110	N.C			
111	GND			
112	GND			
113	TX0p	In	CML	Input Data
114	TX0n	In	CML	Inverted Input Data
115	GND			
116	TX1p	In	CML	Input Data
117	TX1n	In	CML	Inverted Input Data
118	GND			
119	TX2p	In	CML	Input Data
120	TX2n	In	CML	Inverted Input Data
121	GND			
122	TX3p	In	CML	Input Data
123	TX3n	In	CML	Inverted Input Data
124	GND			
125	TX4p	In	CML	Input Data
126	TX4n	In	CML	Inverted Input Data
127	GND			
128	TX5p	In	CML	Input Data
129	TX5n	In	CML	Inverted Input Data
130	GND			
131	TX6p	In	CML	Input Data
132	TX6n	In	CML	Inverted Input Data
133	GND			
134	TX7p	In	CML	Input Data
135	TX7n	In	CML	Inverted Input Data
136	GND			
137	TX8p	In	CML	Input Data
138	TX8n	In	CML	Inverted Input Data
139	GND			
140	TX9p	In	CML	Input Data
141	TX9n	In	CML	Inverted Input Data

142	GND			
143	N.C.			
144	N.C.			
145	GND			
146	REFCLKp	In	CML	Reference Input Clock
147	REFCLKn	In	CML	Reference Inverted Input Clock
148	GND			

Block diagram

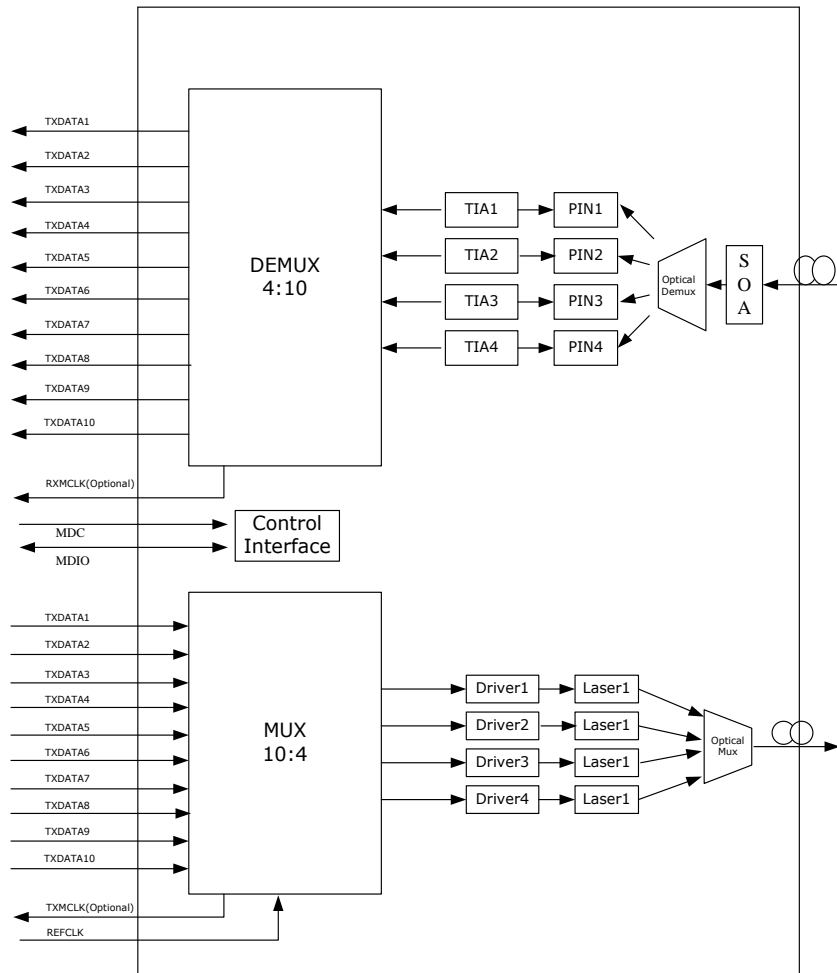

Required Host Board Components

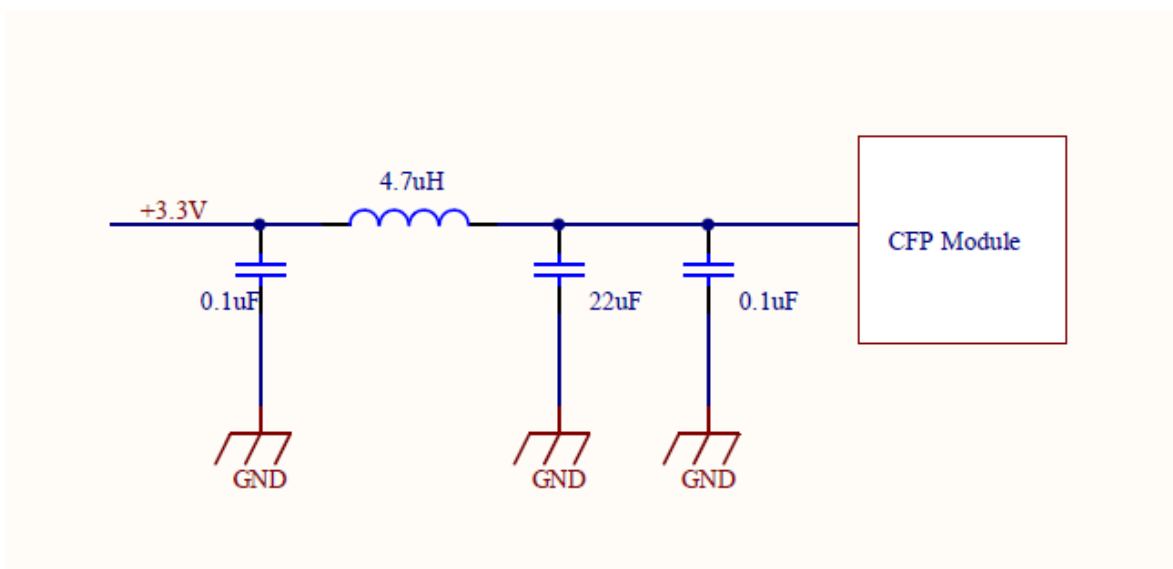

Package outline

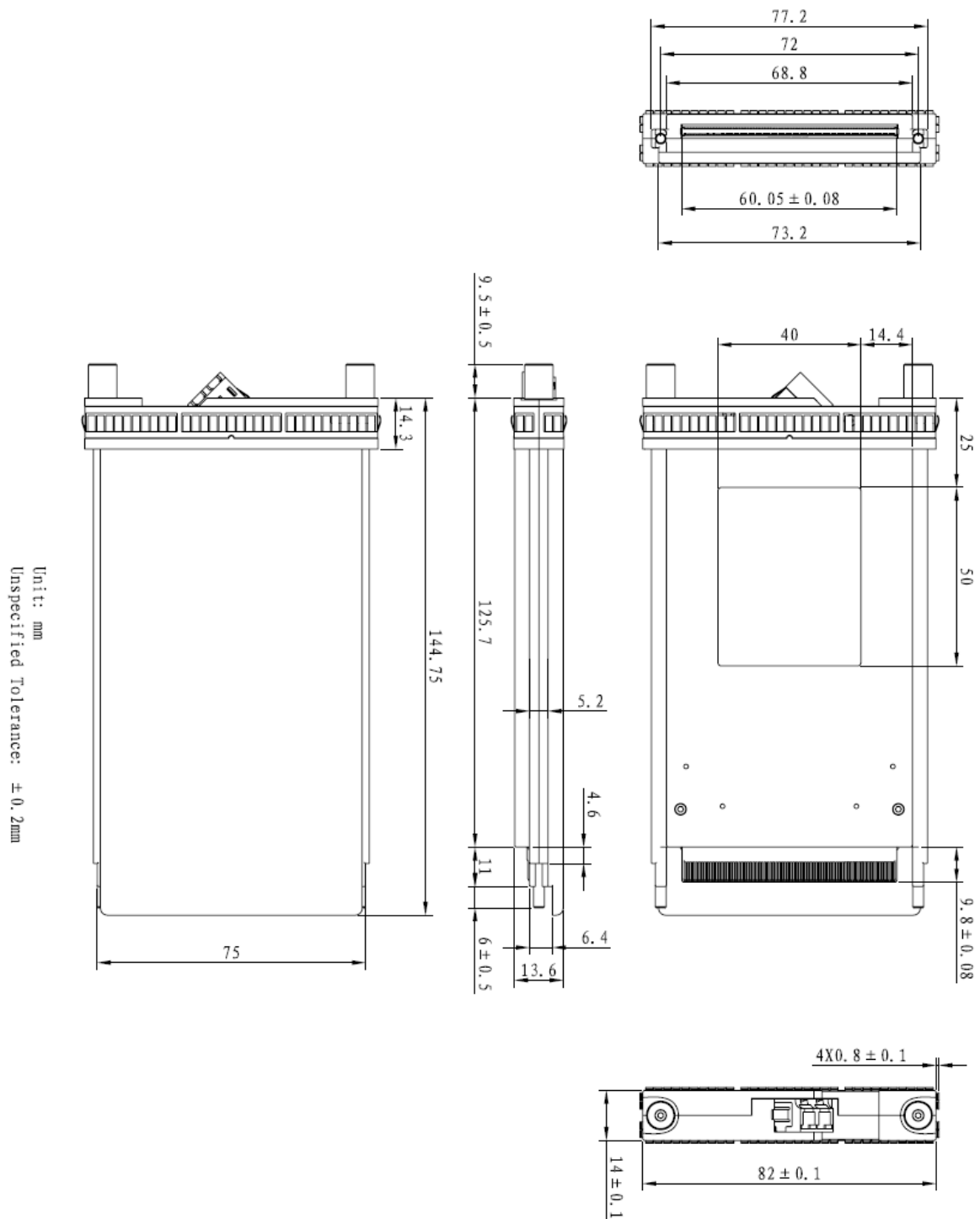

PCB layout recommendation

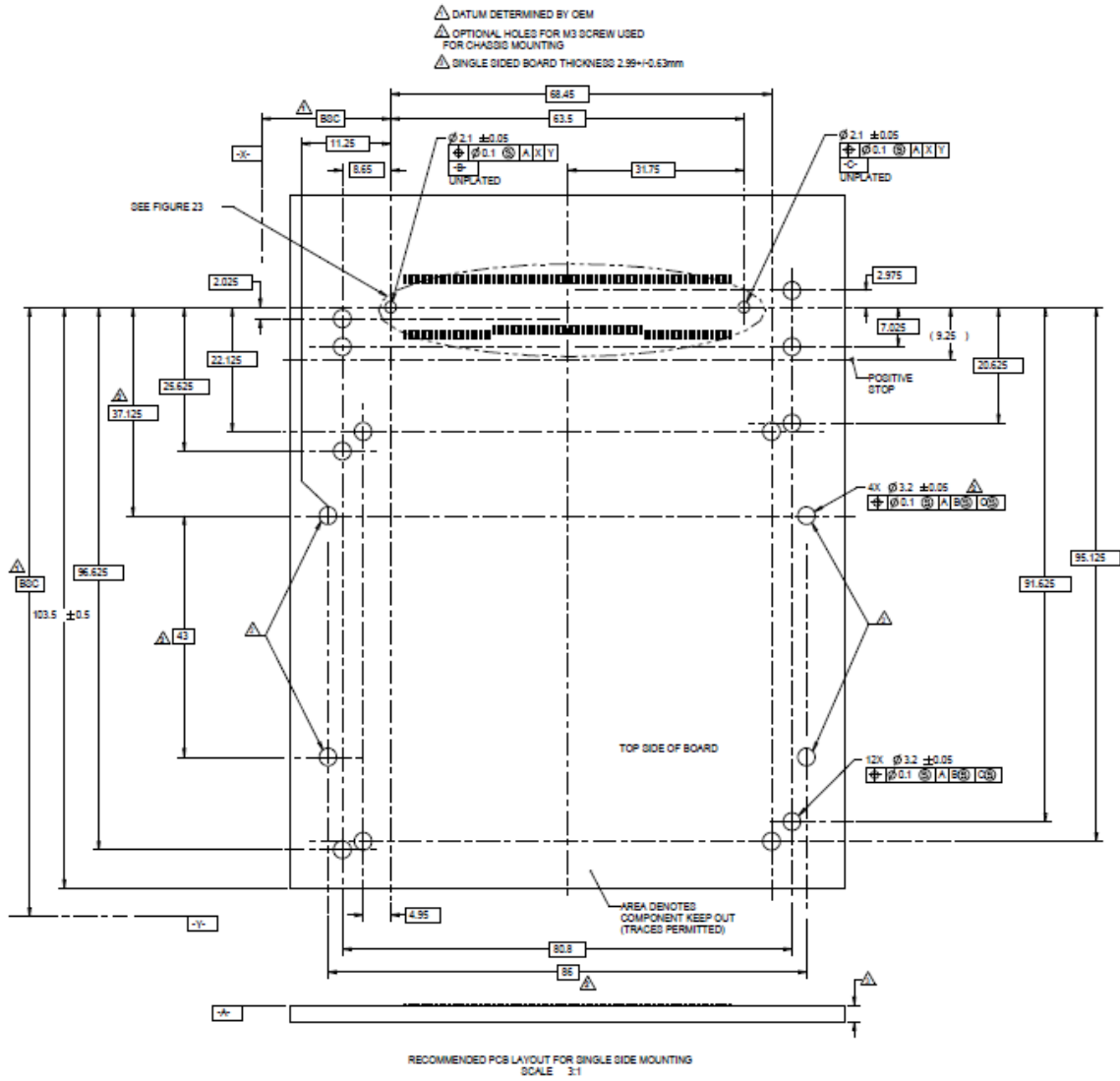

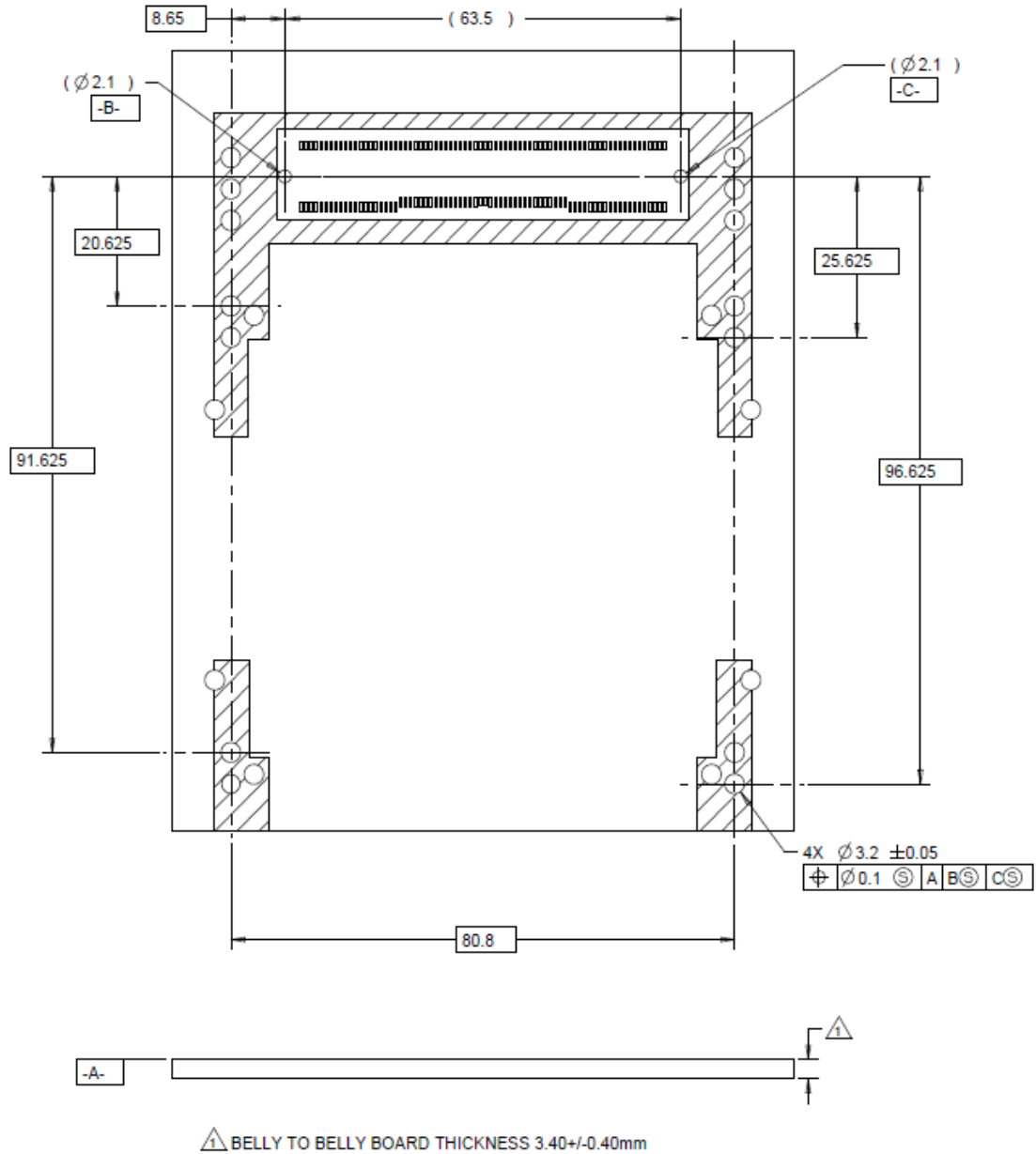
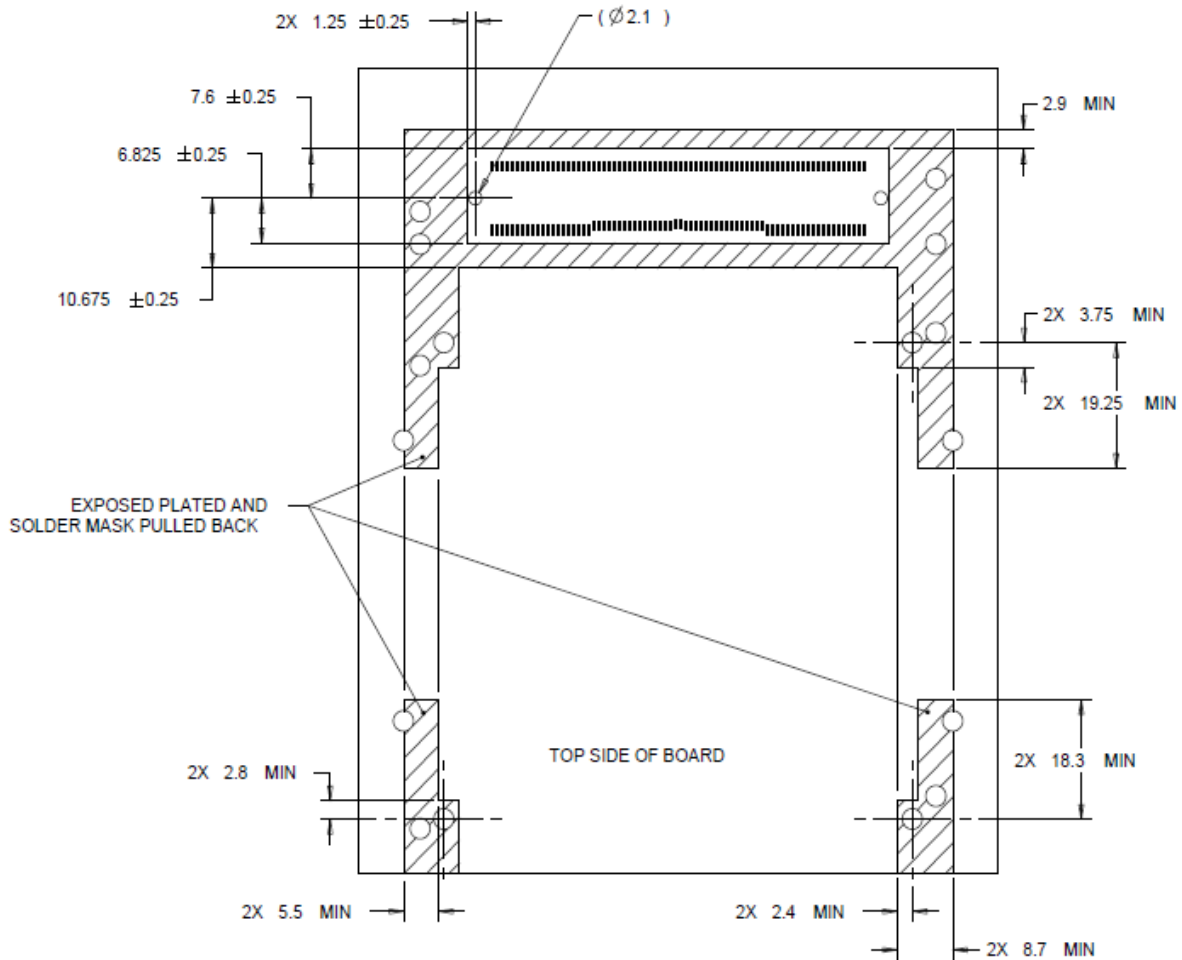

FIGURE 21



Regulatory Compliance

Feature	Test Method	Performance
Electrostatic Discharge (ESD) to the Electrical Pins	MIL-STD-883E Method 3015.7	high speed signal pins shall withstand 500V electrostatic discharge based on Human Body Model per JEDEC JESD22-A114-B the other pins with exception of the high speed signal pins shall withstand 2kV electrostatic discharge based on Human Body Model per JEDEC JESD22-A114-B
Electrostatic Discharge (ESD) Immunity	IEC61000-4-2 Class B	15kV air discharges during operation and 8kV direct contact discharge
Electromagnetic Interference (EMI)	CISPR22 ITE Class B FCC Class B	Compliant with standard

	CENELEC EN55022 VCCI Class 1	
Immunity	IEC61000-4-3 Class 2	Compliant with any electro-magnetic regulations
Safety	FDA CDRH 21-CFR 1040 Class 1	
	UL	
	TUV-GS	
	CE	

Ordering Information

Part No	Specifications									Application Code
	Pack	Data rate	Tx	Pout	Rx	S	Top	Reach	Others	
RTXM290-403	CFP	103.125Gbps	1310nm LAN Cooled EMA DFB-LD	-2.9~+2.9 dBm	PIN	<-19.4dBm	0~70°C	40km	DDM	100GE/OTU4

