

TS-X2-B332710-10D

10 Gigabit BIDI X2 Transceiver

FEATURES

- XAUI Electrical Interface: 4 Lanes @ 3.125Gbit/s
- Uncooled 1330nm DFB laser and 1270nm PIN receiver
- Hot Z-Pluggable
- SC-Duplex Optical Receptacle
- MDIO, DOM Support
- Compliant to X2 MSA
- Compliant to IEEE 802.3ae 10GBASE-LR Application
- Case operating temperature: 0 to 70 °C

REFERENCE

IEEE 802.3ae as 10GBASE-LR, X2 MSA Release1.0B

GENERAL DESCRIPTION

TRANSCOM's 10Gb/s X2 transceiver module TS-X2-B332710-10D is a hot pluggable in the Z-direction module that is usable in typical router line card applications, Storage, IP network and LAN and compliant to X2 MSA. The TS-X2-B332710-10D is a fully integrated 10.3Gbit/s optical transceiver module that consists of a 10.3Gbit/s optical transmitter and receiver, XAUI interface, Mux and Demux with clock and data recovery (CDR). This version of TRANSCOM Inc. transceiver line uses an uncooled 1330nm DML Laser Diode to achieve 10km over standard single mode fiber as 10GBASE-LR of the IEEE 802.3ae.

PERFORMANCE SPECIFICATIONS

I .Optical Characteristics

Table 1. Optical Characteristics

| No. | Parameters | Symbols | Min. | Typ. | Max. | Unit | Remarks |
|-----|--|-------------|------|---------|-------|--------|---------|
| 1 | Center Wavelength | λ_C | 1320 | 1330 | 1340 | nm | |
| 2 | Signaling speed | | - | 10.3125 | - | Gbit/s | |
| 3 | Signaling speed variation from nominal | | -100 | - | +100 | ppm | |
| 4 | Average Optical Power | Pout | -5 | - | 0.5 | dBm | |
| 6 | Side Mode Suppression Ratio | Sr | 30 | - | - | dB | Average |
| 7 | Extinction Ratio | Er | 3.5 | - | - | dB | |
| 8 | Off Transmit Power | Poff | - | - | -30 | dBm | Average |
| 9 | Receiver Sensitivity | | - | | -14.4 | dBm | |
| 10 | Receiver Overload | Rro | +0.5 | - | - | dBm | Average |
| 11 | Optical Centre Wavelength | λ_C | 1260 | 1270 | 1280 | nm | |
| 12 | Los D-Assert | ROSd | | | -18 | dBm | |
| 13 | Los Assert | ROSa | -32 | | | | |
| 11 | Los Hysteresis | | 0.5 | - | - | dB | |

II .Electrical Performance

Table2. Power Supply Characteristics

| No. | Parameter | Symbol | Min. | Typ. | Max. | Unit | Remarks |
|-----|---------------------------------|--------|-------|-------|-------|------|---------|
| 1 | Supply Voltage | VCC1 | 3.135 | 3.300 | 3.465 | V | |
| 2 | Supply Voltage | VCC2 | 1.152 | 1.200 | 1.248 | V | |
| 3 | Supply Current | ICC1 | - | - | 1.0 | A | +3.3 V |
| 4 | Supply Current | ICC2 | - | - | 1.7 | A | APS |
| 5 | Power Consumption | PDS | - | - | 4.0 | W | |
| 6 | Power supply stabilization time | TDF | - | - | 500 | ms | |
| 7 | Initialization Time | TINIT | - | - | 5 | s | |
| 8 | RESET Assert Time | TRESET | 1 | - | - | ms | |

| | | | | | | | |
|---|--------------------------------------|-------|-----|---|---|----|--|
| 9 | Hold Time after rising edge of RESET | THOLD | 500 | - | - | ms | |
|---|--------------------------------------|-------|-----|---|---|----|--|

Table 3. XAUI Driver Characteristics

| No. | Parameter | Symbol | Min. | Typ. | Max. | Unit | Remarks |
|-----|------------------------|--------|------|-------|------|--------|--------------------|
| 1 | Baud Rate | | - | 3.125 | - | Gbit/s | |
| 2 | Baud Rate Tolerance | | -100 | - | +100 | ppm | |
| 3 | Differential Amplitude | | 800 | - | 1600 | mVPP | AC, near-end value |

Table4. 1.2V CMOS Interface Characteristics

| No. | Parameter | Symbol | Min. | Typ. | Max. | Unit | Remarks |
|-----|-------------------------|--------|------|------|------|-------|-------------------------|
| 1 | Input High Voltage | VIH | 0.84 | - | 1.5 | V | |
| 2 | Input Low Voltage | VIL | -0.3 | - | 0.36 | V | |
| 3 | Input Pull-down Current | IIn | 20 | 40 | 120 | μA | Vih=1.2V |
| 4 | Output High Voltage | VOH | 1.0 | - | - | V | Pull-up=10k ohm to 1.2V |
| 5 | Output Low Voltage | VOL | - | - | 0.2 | V | |
| 6 | Pull up Resistance | RLASI | 10 | - | 22 | k ohm | |
| 7 | Capacitance | CLASI | - | - | 10 | pF | |
| 8 | Load Capacitance | CLoad | - | - | 320 | pF | |

Table5. MDIO Bidirectional Interface Characteristics

| No. | Parameter | Symbol | Min. | Typ. | Max. | Unit | Remarks |
|-----|--|---------|------|------|------|------|---------|
| 1 | Input High Voltage | VIHM | 0.84 | - | 1.5 | V | |
| 2 | Input Low Voltage | VILM | -0.3 | - | 0.36 | V | |
| 3 | Output High Voltage | VOHM | 1.0 | - | 1.5 | V | |
| 4 | Output Low Voltage | VOLM | -0.3 | - | 0.2 | V | |
| 5 | Pull up Resistance | RMDIO | 200 | - | | Ohm | |
| 6 | MDC min high/low time | THM,TLM | 160 | - | - | ns | |
| 7 | MDC Frequency | 1/TCK | TBD | - | 2.5 | MHz | |
| 8 | Setup time | TDIS | 10 | - | - | ns | |
| 9 | Hold time | TDIH | 10 | - | - | ns | |
| 10 | MDIO output delay after rising edge of MDC | TPD | 0 | - | 300 | ns | |
| 12 | Input Capacitance | Ci | - | - | 10 | pF | |
| 13 | Bus Loading | CL | - | - | 470 | pF | |

Note: The maximum value of RMDIO depends on bus loading(CL), input capacitance(Ci), and MDC frequency(1/TCK).

III. Electrical Pad Layout

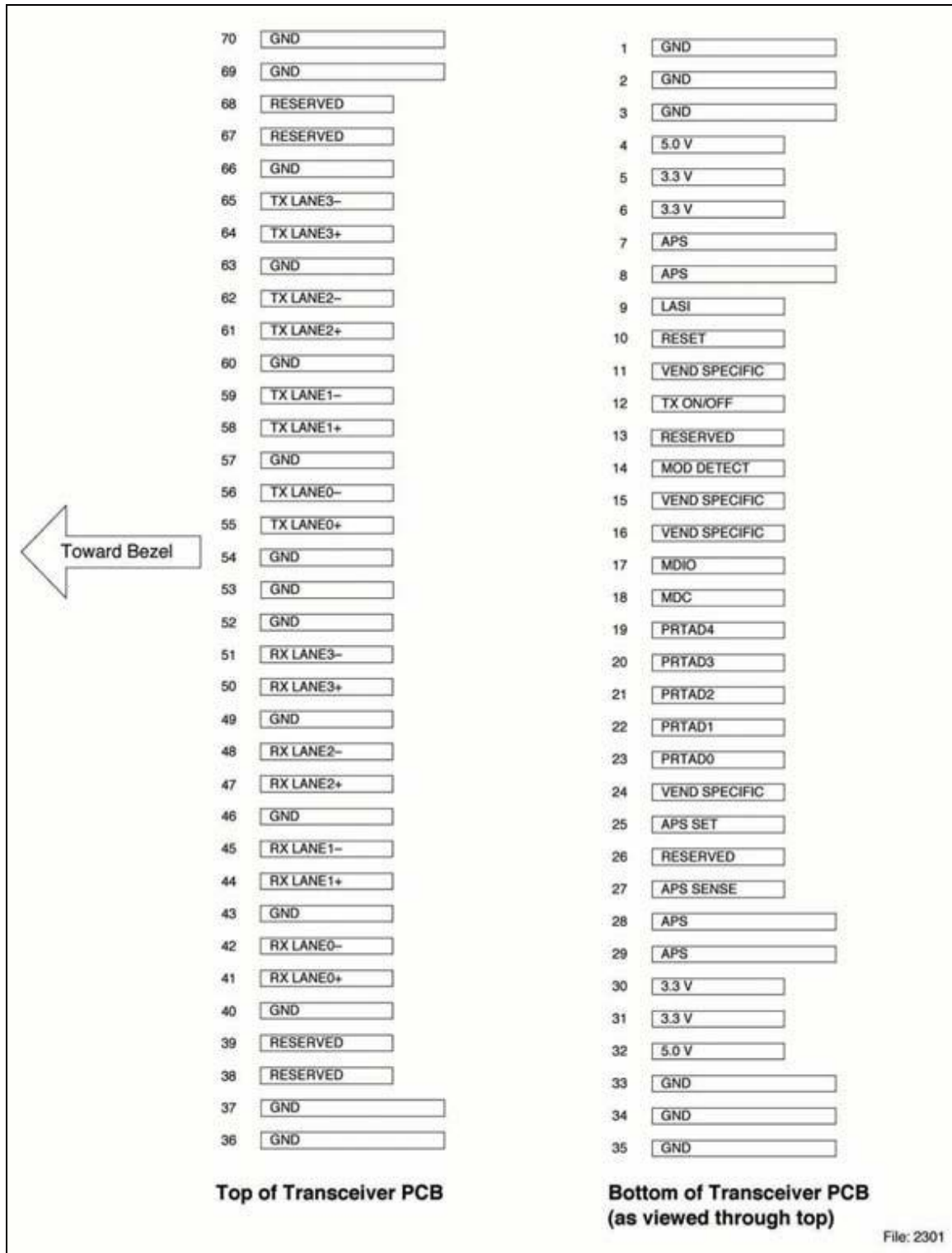

Fig 1-X2 Transponder Electrical Pad Layout

Table6. X2 Pin Configuration

| Pin # | Symbol | I/O | Logic | Description |
|-------|---------------|-----|------------|--|
| 1 | GND | I | Supply | Electrical ground |
| 2 | GND | I | Supply | Electrical ground |
| 3 | GND | I | Supply | Electrical ground |
| 4 | RESERVED | - | - | Reserved |
| 5 | 3.3 V | I | Supply | Power |
| 6 | 3.3 V | I | Supply | Power |
| 7 | APS | I | Supply | Adaptive Power Supply |
| 8 | APS | I | Supply | Adaptive Power Supply |
| 9 | LASI | O | Open Drain | Link Alarm Status Interrupt. 10-22k ohm pull up on host. |
| 10 | RESET | I | 1.2V CMOS | TX OFF when MDIO RESET |
| 11 | VEND SPECIFIC | - | - | Vendor Specific Pin. Leave unconnected. |
| 12 | TX ON/OFF | I | 1.2V CMOS | Transmitter ON/OFF |
| 13 | RESERVED | - | - | Reserved |
| 14 | MOD DETECT | O | - | Pulled low inside module through 1k ohm. |
| 15 | VEND SPECIFIC | - | - | Vendor Specific Pin. Leave unconnected. |
| 16 | VEND SPECIFIC | - | - | Vendor Specific Pin. Leave unconnected. |
| 17 | MDIO | I/O | Open Drain | Management Data IO |
| 18 | MDC | I | 1.2V CMOS | Management Data Clock |
| 19 | PRTAD4 | I | 1.2V CMOS | Port Address bit 4 (Low=0) |
| 20 | PRTAD3 | I | 1.2V CMOS | Port Address bit 3 (Low=0) |
| 21 | PRTAD2 | I | 1.2V CMOS | Port Address bit 2 (Low=0) |
| 22 | PRTAD1 | I | 1.2V CMOS | Port Address bit 1 (Low=0) |
| 23 | PRTAD0 | I | 1.2V CMOS | Port Address bit 0 (Low=0) |
| 24 | VEND SPECIFIC | - | - | Vendor Specific Pin. Leave unconnected. |
| 25 | APS SET | O | - | Feedback output for APS |
| 26 | RESERVED | - | - | Reserved for Avalanche Photodiode use. |
| 27 | APS SENSE | O | Analog | APS Sense Connection |
| 28 | APS | I | Supply | Adaptive Power Supply |
| 29 | APS | I | Supply | Adaptive Power Supply |
| 30 | 3.3 V | I | Supply | Power |
| 31 | 3.3 V | I | Supply | Power |
| 32 | RESERVED | - | - | Reserved |
| 33 | GND | I | Supply | Electrical Ground |
| 34 | GND | I | Supply | Electrical Ground |

| | | | | |
|----|------------|---|--------|----------------------------|
| 35 | GND | I | Supply | Electrical Ground |
| 36 | GND | I | Supply | Electrical Ground |
| 37 | GND | I | Supply | Electrical Ground |
| 38 | RESERVED | - | - | Reserved |
| 39 | RESERVED | - | - | Reserved |
| 40 | GND | I | Supply | Electrical Ground |
| 41 | RX LANE 0+ | O | AC | Module XAUI Output Lane 0+ |
| 42 | RX LANE 0- | O | AC | Module XAUI Output Lane 0- |
| 43 | GND | I | Supply | Electrical Ground |
| 44 | RX LANE 1+ | O | AC | Module XAUI Output Lane 1+ |
| 45 | RX LANE 1- | O | AC | Module XAUI Output Lane 1- |
| 46 | GND | I | Supply | Electrical Ground |
| 47 | RX LANE 2+ | O | AC | Module XAUI Output Lane 2+ |
| 48 | RX LANE 2- | O | AC | Module XAUI Output Lane 2- |
| 49 | GND | I | Supply | Electrical Ground |
| 50 | RX LANE 3+ | O | AC | Module XAUI Output Lane 3+ |
| 51 | RX LANE 3- | O | AC | Module XAUI Output Lane 3- |
| 52 | GND | I | Supply | Electrical Ground |
| 53 | GND | I | Supply | Electrical Ground |
| 54 | GND | I | Supply | Electrical Ground |
| 55 | TX LANE 0+ | I | AC | Module XAUI Input Lane 0+ |
| 56 | TX LANE 0- | I | AC | Module XAUI Input Lane 0- |
| 57 | GND | I | Supply | Electrical Ground |
| 58 | TX LANE 1+ | I | AC | Module XAUI Input Lane 1+ |
| 59 | TX LANE 1- | I | AC | Module XAUI Input Lane 1- |
| 60 | GND | I | Supply | Electrical Ground |
| 61 | TX LANE 2+ | I | AC | Module XAUI Input Lane 2+ |
| 62 | TX LANE 2- | I | AC | Module XAUI Input Lane 2- |
| 63 | GND | I | Supply | Electrical Ground |
| 64 | TX LANE 3+ | I | AC | Module XAUI Input Lane 3+ |
| 65 | TX LANE 3- | I | AC | Module XAUI Input Lane 3- |
| 66 | GND | I | Supply | Electrical Ground |
| 67 | RESERVED | - | - | Reserved |
| 68 | RESERVED | - | - | Reserved |
| 69 | GND | I | Supply | Electrical Ground |

| | | | | |
|----|-----|---|--------|-------------------|
| 70 | GND | I | Supply | Electrical Ground |
|----|-----|---|--------|-------------------|

Note: Case is connected to electrical ground in the module.

IV. Package Outline

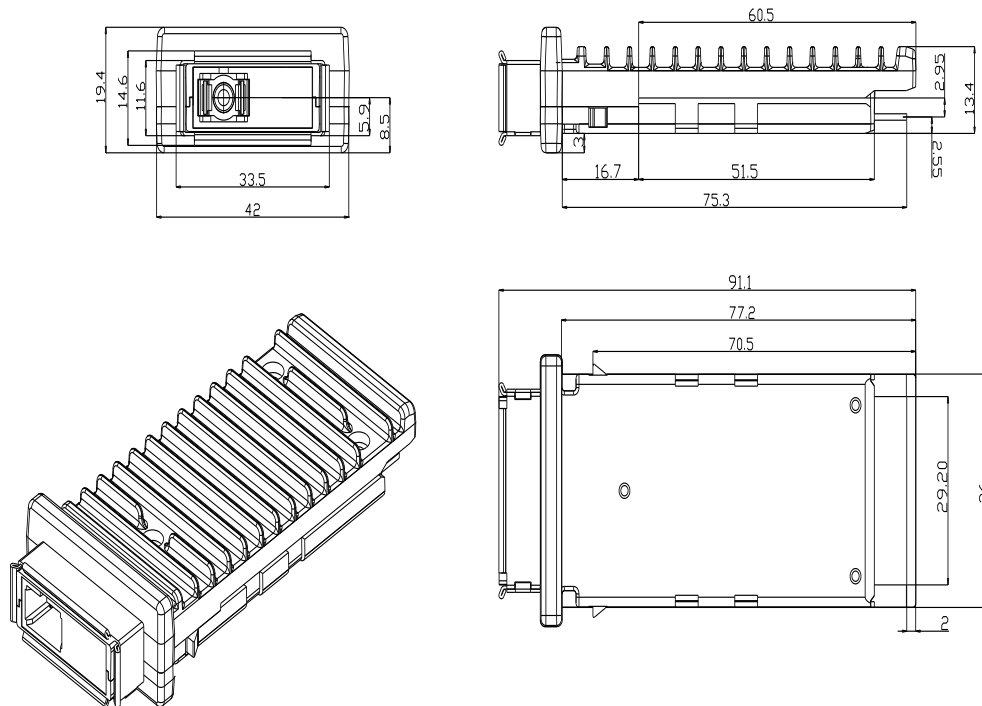

Figure 1 Mechanical dimensions

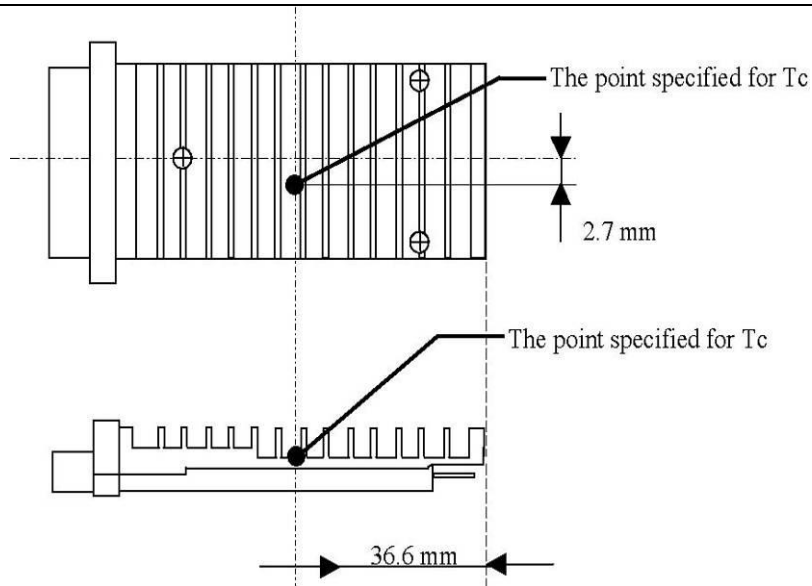

Figure 2 The Point Specified for Case Temperature (Tc)

V. Register Definition

| Device Address (Dec) Register Address (Hex) | PMA/PMD 1 | PCS 3 | PHY TS 4 |
|---|-----------------------------|------------------------|---------------------------|
| 0x0000 | PMA/PMD Control1 | PCS Control1 | PHY TS Control1 |
| 0x0001 | PMA/PMD Status1 | PCS Status1 | PHY TS Status1 |
| 0x0002 | PMA/PMD Device Identifier0 | PCS Device Identifier0 | PHY TS Device Identifier0 |
| 0x0003 | PMA/PMD Device Identifier1 | PCS Device Identifier1 | PHY TS Device Identifier1 |
| 0x0004 | PMA/PMD Speed Ability | PCS Speed Ability | PHY TS Speed Ability |
| 0x0005 | PMA/PMD Device in Package1 | PCS Device in Package1 | PHY TS Device in Package1 |
| 0x0006 | PMA/PMD Device in Package2 | PCS Device in Package2 | PHY TS Device in Package2 |
| 0x0007 | 10G PMA/PMD Control2 | PCS Control2 | Reserved |
| 0x0008 | 10G PMA/PMD Status2 | PCS Status2 | PHY TS Status2 |
| 0x0009 | 10G PMD Transmit Disable | Reserved | Reserved |
| 0x000A | 10G PMD Receive Signal O.K. | Reserved | Reserved |
| 0x000E | Package Identifier0 | Reserved | Reserved |
| 0x000F | Package Identifier1 | Reserved | Reserved |
| 0x0018 | Reserved | Reserved | 10G PHY TS Lane Status |
| 0x0019 | Reserved | Reserved | 10G PHY TS Test Control |
| 0x0020 | Reserved | 10GBASE-R PCS Status1 | Reserved |
| 0x0021 | Reserved | 10GBASE-R PCS Status2 | Reserved |

| | | | |
|-----------------|---|--|----------|
| 0x0022 | Reserved | 10GBASE-R PCS Test pattern Seed A0 | Reserved |
| 0x0023 | Reserved | 10GBASE-R PCS Test pattern Seed A1 | Reserved |
| 0x0024 | Reserved | 10GBASE-R PCS Test pattern Seed A2 | Reserved |
| 0x0025 | Reserved | 10GBASE-R PCS Test pattern Seed A3 | Reserved |
| 0x0026 | Reserved | 10GBASE-R PCS Test pattern Seed B0 | Reserved |
| 0x0027 | Reserved | 10GBASE-R PCS Test pattern Seed B1 | Reserved |
| 0x0028 | Reserved | 10GBASE-R PCS Test pattern Seed B2 | Reserved |
| 0x0029 | Reserved | 10GBASE-R PCS Test pattern Seed B3 | Reserved |
| 0x002A | Reserved | 10GBASE-R PCS Test pattern Control | Reserved |
| 0x002B | Reserved | 10GBASE-R PCS Test pattern Error counter | Reserved |
| 0x8000 | NVR Control/Status (X2 Register) | | Reserved |
| 0x8007 - 0x807D | NVR (X2 Register) | | Reserved |
| 0x807E- 0x80AD | Customer AREA | | Reserved |
| 0x80AE - 0x8106 | TRANSCOM Specific Area(X2 Register) | | Reserved |
| 0x9000 | RX_ALARM Control (X2 Register) | | Reserved |
| 0x9001 | TX_ALARM Control (X2 Register) | | Reserved |
| 0x9002 | LASI Control (X2 Register) | | Reserved |
| 0x9003 | RX_ALARM Status (X2 Register) | | Reserved |
| 0x9004 | TX_ALARM Status (X2 Register) | | Reserved |
| 0x9005 | LASI Status (X2 Register) | | Reserved |
| 0x9006 | TX_FLAG Control Bits | | Reserved |
| 0x9007 | RX_FLAG Control Bits | | Reserved |
| 0xA000 - 0xA027 | Alarm and Warning Thresholds | | Reserved |
| 0xA060 - 0xA069 | Digital Optical Monitoring Interface | | Reserved |
| 0xA06F | DOM Capability - Extended | | Reserved |
| 0xA070 | TX_ALARM_FLAG Bits | | Reserved |
| 0xA071 | RX_ALARM_FLAG Bits | | Reserved |
| 0xA074 | TX_WARNING_FLAG Bits | | Reserved |
| 0xA075 | RX_WARNING_FLAG Bits | | Reserved |
| 0xA100 | Optional Digital Optical Monitoring (DOM) Control/Status | | Reserved |

VI. Regulatory Compliance

| Feature | Reference | Performance |
|------------------------------------|---|---------------------------|
| Electrostatic discharge (ESD) | IEC/EN 61000-4-2 | Compatible with standards |
| Electromagnetic Interference (EMI) | FCC Part 15 Class B EN 55022 Class B (CISPR 22A) | Compatible with standards |
| Laser Eye Safety | FDA 21CFR 1040.10, 1040.11 IEC/EN 60825-1, 2 | Class 1 laser product |
| ROHS | 2002/95/EC | Compatible with standards |
| EMC | EN61000-3 | Compatible with standards |

Appendix A. Document Revision

| Version No. | Date | Description |
|--------------------|-------------|----------------------------------|
| 1.0 | 2010-09-01 | Preliminary datasheet |
| 2.0 | 2011-09-10 | Update format and company's logo |