

TS-XF-8510-02D

10Gb/s 850nm Multimode XFP Optical Transceiver

PRODUCT FEATURES

- Hot-pluggable XFP footprint
- Supports 9.95Gb/s to 11.3Gb/s bit rates
- XFI Loopback Mode
- Power dissipation <1.5W
- RoHS-6 compliant (lead-free)
- Case Temperature range -5 °C to 70 °C
- Maximum link length of 300m
- Uncooled 850nm VCSEL laser
- Duplex LC connector
- No Reference Clock required
- Built-in digital diagnostic functions
- Standard bail release mechanism



APPLICATIONS

- 10GBASE-SR/SW 10G Ethernet
- 1200-Mx-SN-I 10G Fiber Channel

PRODUCT DESCRIPTION

TRANSCOM's TS-XF-8510-02D Small Form Factor 10Gb/s (XFP) transceivers are compliant with the current XFP Multi-Source Agreement (MSA) Specification. They comply with 10-Gigabit Ethernet 10GBASE-SR/SW per IEEE 802.3ae and 10G Fiber Channel 1200-Mx-SN-I. Digital diagnostics functions are available via a 2-wire serial interface, as specified in the XFP MSA.

I. Absolute Maximum Ratings

Parameter	Symbol	Min	Typ	Max	Unit	Ref.
Maximum Supply Voltage	Vcc3	-0.5		4.0	V	
Storage Temperature	T _s	-40		85	°C	
Case Operating Temperature	T _{case}	-5		70	°C	

II. Electrical Characteristics (T_{OP} = -5 to 70 °C, V_{CC3} = 3.13 to 3.45 Volts)

Parameter	Symbol	Min	Typ	Max	Unit	Ref.
Supply Voltage	Vcc3	3.13		3.45	V	
Supply Current	Icc3			350	mA	
Module total power	P			1.5	W	1
Transmitter						
Input differential impedance	R _{in}		100		Ω	2
Differential data input swing	V _{in,pp}	120		1000	mV	
Transmit Disable Voltage	V _D	2.0		V _{cc}	V	3
Transmit Enable Voltage	V _{EN}	GND		GND+ 0.8	V	
Transmit Disable Assert Time				10	us	
Receiver						
Differential data output swing	V _{out,pp}	600	650	800	mV	4
Data output rise time	t _r			40	ps	5
Data output fall time	t _f			40	ps	5
LOS Fault	V _{LOS fault}	V _{cc} – 0.5		V _{cc} _{HOST}	V	6
LOS Normal	V _{LOS norm}	GND		GND+0.5	V	6
Power Supply Rejection	PSR					7

Notes:

- Maximum total power value is specified across the full temperature and voltage range.
- After internal AC coupling.
- Or open circuit.
- Into 100 ohms differential termination.
- These are unfiltered 20-80% values
- Loss Of Signal is open collector to be pulled up with a 4.7kΩ – 10kΩ resistor to 3.15 – 3.6V. Logic 0 indicates normal operation; logic 1 indicates no signal detected.
- Per Section 2.7.1. in the XFP MSA Specification¹.

III. Optical Characteristics ($T_{OP} = -5$ to 70 °C, $V_{CC3} = 3.13$ to 3.45 Volts)

Parameter	Symbol	Min	Typ	Max	Unit	Ref.
Transmitter						
Average Optical Power	P_{AVE}	-6		-1.0		1
Optical Wavelength	λ	840	850	860	nm	
Optical Extinction Ratio	ER	3.0	5		dB	
Transmitter and Dispersion Penalty	TDP			3.9	dB	
Average Launch power of transmitter	P_{OFF}			-30	dBm	
Tx Jitter	T_{X_j}				Per 802.3ae requirements	
Encircled Flux	$<4.5\mu m$			30	%	2
Relative Intensity Noise	$RIN_{OMA_{12}}$			-128	dB/Hz	
Receiver						
Receiver Sensitivity@ 10.5Gb/s	R_{SENS}			-10	dBm	
Input Saturation Power (Overload)	$Psat$	+0.5			dBm	
Wavelength Range	λ_C	840		860	nm	
Receiver Reflectance	R_{rx}			-12	dB	
LOS De-Assert	LOS_D			-12	dBm	
LOS Assert	LOS_A	-30			dBm	
LOS Hysteresis		0.5			dB	

Notes:

1. Average power figures are informative only, per IEEE 802.3ae.
2. Measured into Type A1a (50/125 μm multimode) fiber per ANSI/TIA/EIA-455-203-2.

IV. Pin Assignment

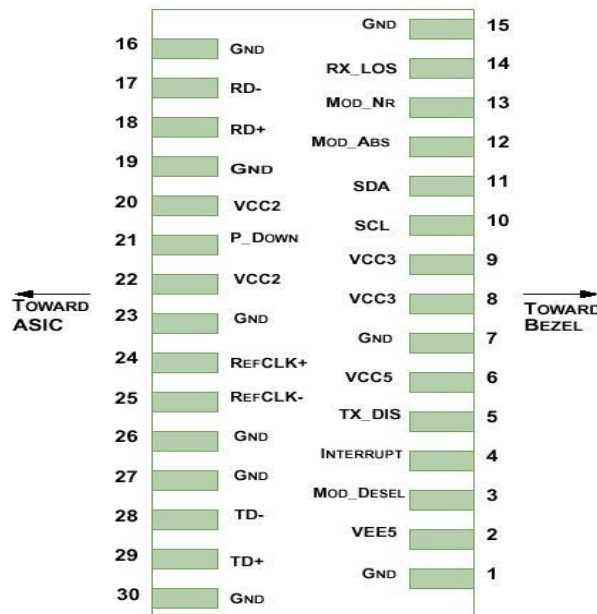

Diagram of Host Board Connector Block Pin Numbers and Name

Pin	Logic	Symbol	Name/Description	Ref.
1		GND	Module Ground	1
2		VEE5	Optional -5.2 Power Supply – Not required	
3	LVTTL-I	Mod-Desel	Module De-select; When held low allows the module to respond to 2-wire serial interface commands	
4	LVTTL-O	Interrupt	Interrupt (bar); Indicates presence of an important condition which can be read over the serial 2-wire interface	2
5	LVTTL-I	TX_DIS	Transmitter Disable; Transmitter laser source turned off	
6		VCC5	+5 Power Supply – Not required	
7		GND	Module Ground	1
8		VCC3	+3.3V Power Supply	
9		VCC3	+3.3V Power Supply	
10	LVTTL-I	SCL	Serial 2-wire interface clock	
11	LVTTL-I/O	SDA	Serial 2-wire interface data line	2
12	LVTTL-O	Mod_Abs	Module Absent; Indicates module is not present. Grounded in the module.	2
13	LVTTL-O	Mod_NR	Module Not Ready; TRANSCOM's defines it as a logical OR between RX_LOS and Loss of Lock in TX/RX.	2
14	LVTTL-O	RX_LOS	Receiver Loss of Signal indicator	2
15		GND	Module Ground	1
16		GND	Module Ground	1
17	CML-O	RD-	Receiver inverted data output	
18	CML-O	RD+	Receiver non-inverted data output	
19		GND	Module Ground	1
20		VCC2	+1.8V Power Supply – Not required	
21	LVTTL-I	P_Down/RST	Power Down; When high, places the module in the low power stand-by mode and on the falling edge of P_Down initiates a module reset	
			Reset; The falling edge initiates a complete reset of the module including the 2-wire serial interface, equivalent to a power cycle.	
22		VCC2	+1.8V Power Supply – Not required	
23		GND	Module Ground	1
24	PECL-I	RefCLK+	Reference Clock non-inverted input, AC coupled on the host board – Not required	3
25	PECL-I	RefCLK-	Reference Clock inverted input, AC coupled on the host board – Not required	3
26		GND	Module Ground	1
27		GND	Module Ground	1
28	CML-I	TD-	Transmitter inverted data input	
29	CML-I	TD+	Transmitter non-inverted data input	
30		GND	Module Ground	1

Notes:

1. Module circuit ground is isolated from module chassis ground within the module.
2. Open collector; should be pulled up with 4.7kΩ – 10kΩ on host board to a voltage between 3.15V and 3.6V.
3. A Reference Clock input is not required by the TS-XF-8510-02D. If present, it will be ignored.

V. General Specifications

Parameter		Symbol	Min	Typ	Max	Units	Ref.		
Bit Rate		BR	9.95		11.3	Gb/s	1		
Bit Error Ratio		BER			10 ⁻¹²		2		
Maximum Supported Distances									
Fiber Type	850nm OFL Bandwidth								
62.5μm	160MHz-km		Lmax			m			
	OM1 500MHz-km							26	33
50μm	400MHz-km		Lmax			m			
	OM2 500MHz-km							66	82
	OM3 2000MHz-km							300	

Notes:

1. 10GBASE-SR/SW, 1200-Mx-SN-I
2. Tested with 10.3Gbps, 2³¹ - 1 PRBS

VI. Digital Diagnostic Functions

As defined by the XFP MSA¹, TRANSCOM XFP transceivers provide digital diagnostic functions via a 2-wire serial interface, which allows real-time access to the following operating parameters:

- Transceiver temperature
- Laser bias current
- Transmitted optical power
- Received optical power
- Transceiver supply voltage

It also provides a sophisticated system of alarm and warning flags, which may be used to alert end-users when particular operating parameters are outside of a factory-set normal range.

The operating and diagnostics information is monitored and reported by a Digital Diagnostics Transceiver Controller (DDTC) inside the transceiver, which is accessed through the 2-wire serial interface. When the serial protocol is activated, the serial clock signal (SCL pin) is generated by the host. The positive edge clocks data into the XFP transceiver into those segments of its memory map that are not write-protected. The negative edge clocks data from the XFP transceiver. The serial data signal (SDA pin) is bi-directional for serial data transfer. The host uses SDA in conjunction with SCL to mark the start and end of serial protocol activation. The memories are organized as a series of 8-bit data words that can be addressed individually or sequentially. The 2-wire serial interface provides sequential or random access to the 8 bit parameters, addressed from 000h to the maximum address of the memory.

For more detailed information including memory map definitions, please see TRANSCOM's

Application Note AN-2035 “Digital Diagnostic Monitoring Interface for XFP Optical Transceivers”, or the XFP MSA Specification1.

VII. Mechanical Specifications

TRANSCOM’s XFP transceivers are compliant with the dimensions defined by the XFP Multi-Sourcing Agreement (MSA). Bail color is beige.

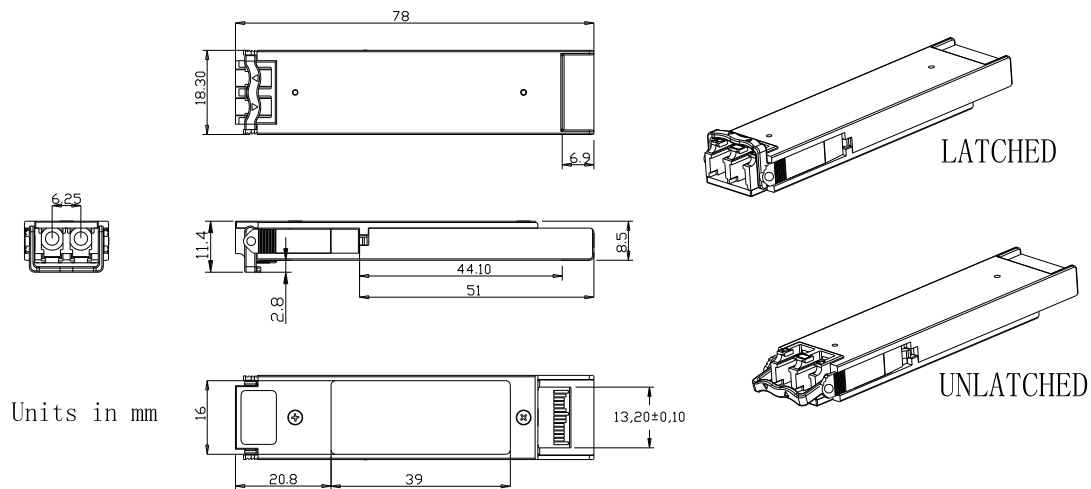

XFP Transceiver (dimensions are in mm)

VIII. PCB Layout and Bezel Recommendations

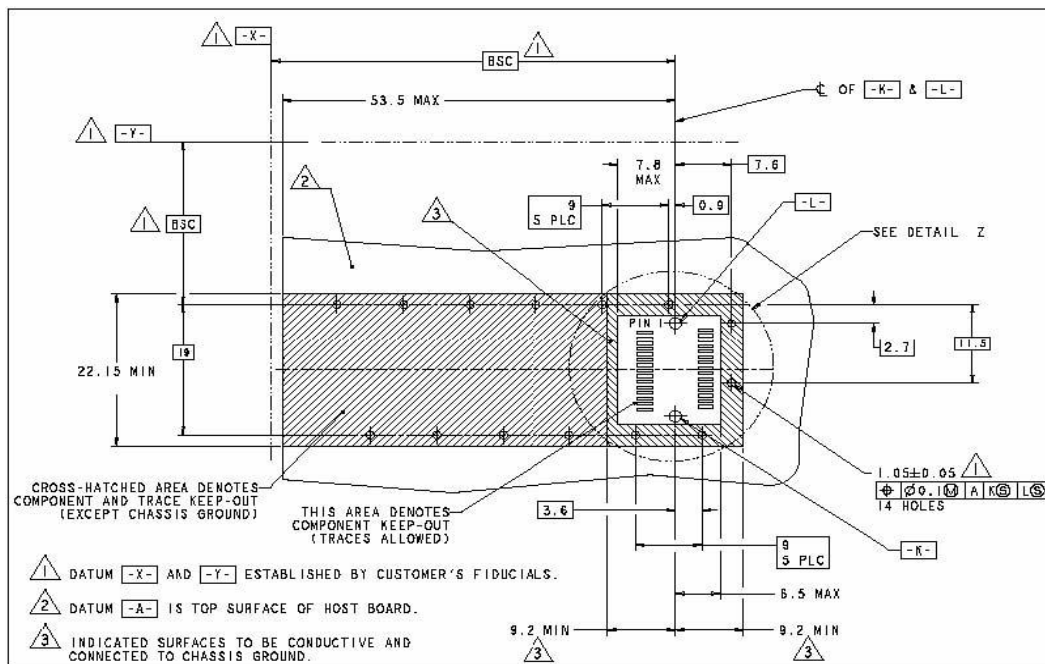

XFP Host Board Mechanical Layout (dimensions are in mm)

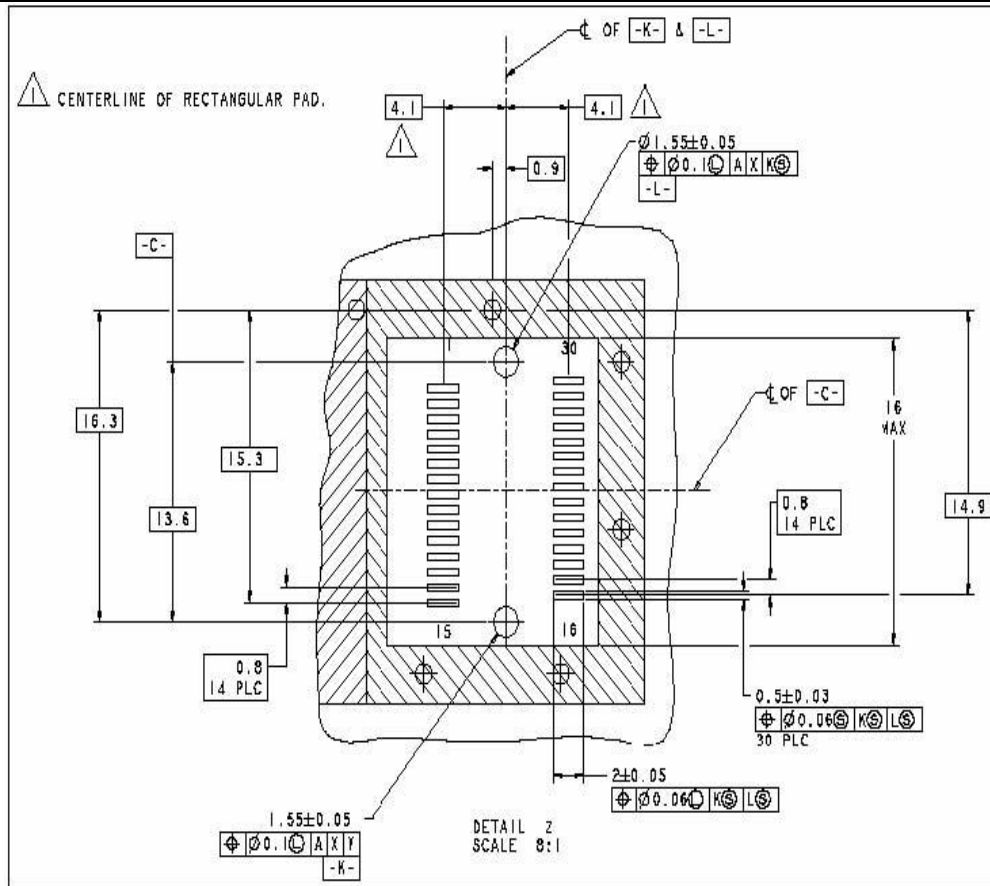

XFP Detail Host Board Mechanical Layout (dimensions are in mm)

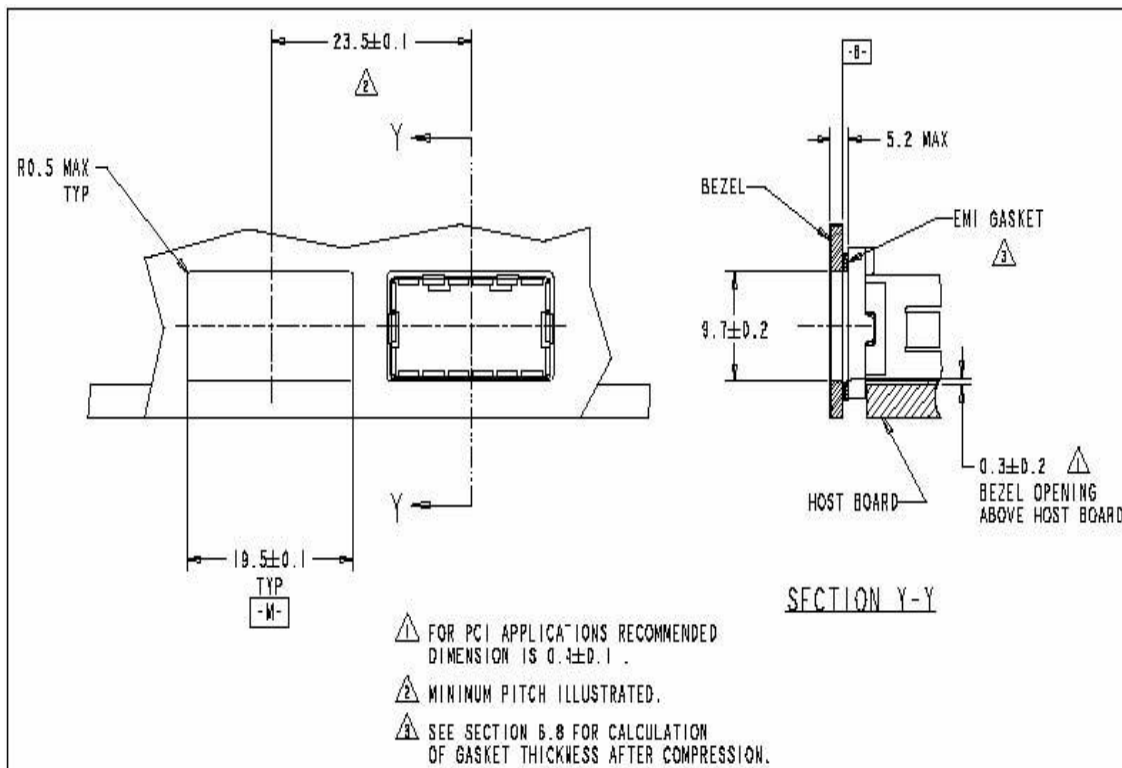

XFP Recommended Bezel Design (dimensions are in mm)

IX. Regulatory Compliance

Feature	Reference	Performance
Electrostatic discharge (ESD)	IEC/EN 61000-4-2	Compatible with standards
Electromagnetic Interference (EMI)	FCC Part 15 Class B EN 55022 Class B (CISPR 22A)	Compatible with standards
Laser Eye Safety	FDA 21CFR 1040.10, 1040.11 IEC/EN 60825-1, 2	Class 1 laser product
Component Recognition	IEC/EN 60950 , UL	Compatible with standards
ROHS	2002/95/EC	Compatible with standards
EMC	EN61000-3	Compatible with standards

Appendix A. Document Revision

Version No.	Date	Description
1.0	2010-09-01	Preliminary datasheet
2.0	2011-09-10	Update format and company's logo