

## **TS-XF-CXX10-40D**

### **10Gb/s 40km CWDM XFP Optical Transceiver**

#### **PRODUCT FEATURES**

- Hot-pluggable XFP footprint
- Supports 9.95Gb/s to 11.3Gb/s bit rates
- Supports Lineside and XFI loopback
- RoHS-6 Compliant (lead-free)
- Power dissipation <3.5W
- Case temperature range:0 ℃ to 70 ℃
- Maximum link length of 40km
- Cooled CWDM EML and PIN receiver
- Full Duplex LC connector
- No Reference Clock required
- Built-in digital diagnostic functions
- Standard bail release mechanism



#### **APPLICATIONS**

- 10GBASE-ER/EW 10G Ethernet
- 10G Fiber Channel
- SONET OC-192 &SDH STM 64

## PRODUCT DESCRIPTION

Transcom's TS-XF-CXX10-40D Small Form Factor 10Gb/s (XFP) transceivers are compliant with the current XFP Multi-Source Agreement (MSA) Specification. They comply with 10-Gigabit Ethernet 10GBASE-ER/EW per IEEE 802.3ae and 10G Fiber Channel 40KM. Digital diagnostics functions are available via a 2-wire serial interface, as specified in the XFP MSA. The transceiver is RoHS compliant and leads free per Directive 2002/95/EC.

## PRODUCT SELECTION

### TS-XF-CXX10-40D

Wavelength	xx	Clasp Color Code	Wavelength	xx	Clasp Color Code
1470 nm	47	Gray	1550 nm	55	Yellow
1490 nm	49	Purple	1570 nm	57	Orange
1510 nm	51	Blue	1590 nm	59	Red
1530 nm	53	Green	1610 nm	61	Brown

## I . Absolute Maximum Ratings

Parameter	Symbol	Min	Typ	Max	Unit	NOTE
Maximum Supply Voltage 1	Vcc3	-0.5		4.0	V	
Maximum Supply Voltage 2	Vcc5	-0.5		6.0	V	
Storage Temperature	Ts	-40		85	°C	
Case Operating Temperature	Tcase	0		70	°C	

## II. Electrical Characteristics

Parameter	Symbol	Min	Typ	Max	Unit	NOTE
Main Supply Voltage	Vcc5	4.75		5.25	V	
Supply Voltage #2	Vcc3	3.13		3.45	V	
Supply Current – Vcc5 supply	Icc5			320	mA	
Supply Current – Vcc3 supply	Icc3			450	mA	
Module total power	P			3.5	W	1
<b>Transmitter</b>						
Input differential impedance	Rin		100		Ω	2
Differential data input swing	Vin,pp	120		820	mV	
Transmit Disable Voltage	VD	2.0		Vcc	V	3

Transmit Enable Voltage	V <sub>EN</sub>	GND		GND+ 0.8	V	
Transmit Disable Assert Time				10	us	
<b>Receiver</b>						
Differential data output swing	V <sub>out,pp</sub>	340	650	850	mV	4
Data output rise time	t <sub>r</sub>			38	ps	5
Data output fall time	t <sub>f</sub>			38	ps	5
LOS Fault	V <sub>LOS fault</sub>	V <sub>cc</sub> – 0.5		V <sub>ccHOST</sub>	V	6
LOS Normal	V <sub>LOS norm</sub>	GND		GND+0.5	V	6
Power Supply Rejection	PSR		See Note 6 below			7

Notes:

1. Maximum total power value is specified across the full temperature and voltage range.
2. After internal AC coupling.
3. Or open circuit.
4. Into 100 ohms differential termination.
5. These are unfiltered 20-80% values
6. Loss Of Signal is open collector to be pulled up with a 4.7k – 10kohm resistor to 3.15 – 3.6V. Logic 0 indicates normal operation; logic 1 indicates no signal detected.
7. Per Section 2.7.1. in the XFP MSA Specification1.

### III. Optical Characteristics

Parameter	Symbol	Min	Typ	Max	Unit	NOTE
<b>Transmitter</b>						
Average Optical Power	P <sub>f</sub>	-1		4	dBm	
Optical Wavelength	λ	λ -6.5		λ +6.5	nm	1
Side mode Suppression ratio	SMSR	30			dB	
Optical Extinction Ratio	ER	8.2			dB	
Transmitter and Dispersion Penalty	TDP			2	dB	
Average Launch power of OFF transmitter	P <sub>OFF</sub>			-30	dBm	
Tx Jitter	T <sub>xj</sub>	Compliant with 802.3ae requirements				
<b>Receiver</b>						
Receiver Sensitivity	P <sub>sen</sub>			-16.5	dBm	2
Input Saturation Power (Overload)	P <sub>sat</sub>	+0.5			dBm	
Wavelength Range	λ <sub>c</sub>	1270		1610	nm	
Receiver Reflectance	R <sub>rx</sub>			-27	dB	
LOS De-Assert	LOS <sub>D</sub>			-18	dBm	
LOS Assert	LOS <sub>A</sub>	-32			dBm	
LOS Hysteresis		0.5			dB	

Notes:

1. “λ” is:1470, 1490, 1510, 1530, 1550, 1570, 1590, 1610, please the “product selection” .
2. Measured with BER<math>10^{-12}</math> @10.3Gbps,  $2^{31} - 1$  PRBS.

## IV. Pin Assignment

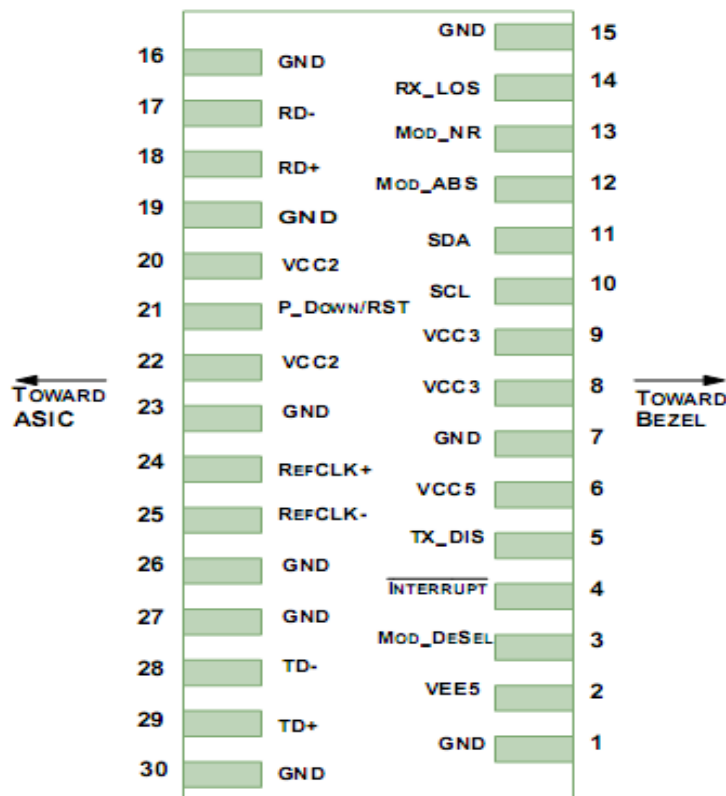

Diagram of Host Board Connector Block Pin Numbers and Name

Pin	Logic	Symbol	Name/Description	NOTE
1		GND	Module Ground	1
2		VEE5	Optional -5.2 Power Supply – <b>Not required</b>	
3	LVTTL-I	Mod-Desel	Module De-select; When held low allows the module to respond to 2-wire serial interface commands	
4	LVTTL-O	Interrupt	Interrupt (bar); Indicates presence of an important condition which can be read over the serial 2-wire interface	2

5	LVTTL-I	TX_DIS	Transmitter Disable; Transmitter laser source turned off	
6		VCC5	+5 Power Supply	
7		GND	Module Ground	1
8		VCC3	+3.3V Power Supply	
9		VCC3	+3.3V Power Supply	
10	LVTTL-I	SCL	Serial 2-wire interface clock	2
11	LVTTL/I/O	SDA	Serial 2-wire interface data line	2
12	LVTTL-O	Mod_Abs	Module Absent; Indicates module is not present. Grounded in the module.	2
13	LVTTL-O	Mod_NR	Module Not Ready; XGIGA defines it as a logical OR between RX_LOS and Loss of Lock in TX/RX.	2
14	LVTTL-O	RX_LOS	Receiver Loss of Signal indicator	2
15		GND	Module Ground	1
16		GND	Module Ground	1
17	CML-O	RD-	Receiver inverted data output	
18	CML-O	RD+	Receiver non-inverted data output	
19		GND	Module Ground	1
20		VCC2	+1.8V Power Supply – <b>Not required</b>	
21	LVTTL-I	P_Down/RST	Power Down; When high, places the module in the low power stand-by mode and on the falling edge of P_Down initiates a module reset	
			Reset; The falling edge initiates a complete reset of the module including the 2-wire serial interface, equivalent to a power cycle.	
22		VCC2	+1.8V Power Supply – <b>Not required</b>	
23		GND	Module Ground	1
24	PECL-I	RefCLK+	Reference Clock non-inverted input, AC coupled on the host board – <b>Not required</b>	3
25	PECL-I	RefCLK-	Reference Clock inverted input, AC coupled on the host board – <b>Not required</b>	3
26		GND	Module Ground	1
27		GND	Module Ground	1
28	CML-I	TD-	Transmitter inverted data input	
29	CML-I	TD+	Transmitter non-inverted data input	

30		GND	Module Ground	1
----	--	-----	---------------	---

Notes:

1. Module circuit ground is isolated from module chassis ground within the module.
2. Open collector; should be pulled up with 4.7k – 10kohms on host board to a voltage between 3.15V and 3.6V.
3. A Reference Clock input is not required by the XFP-10GER. If present, it will be ignored.

## V. General Specifications

Parameter	Symbol	Min	Typ	Max	Units	NOTE
Bit Rate	BR	9.95		11.3	Gb/s	1
Bit Error Ratio	BER			10 <sup>-12</sup>		2
Max. Supported Link Length	L <sub>MAX</sub>			40	km	1

Notes:

1. 10GBASE-ER/EW.
2. Tested with 10.3Gbps, 2<sup>31</sup> – 1 PRBS

## VI. Digital Diagnostic Functions

As defined by the XFP MSA, Transcom XFP transceivers provide digital diagnostic functions via a 2-wire serial interface, which allows real-time access to the following operating parameters:

- Transceiver temperature
- Laser bias current
- Transmitted optical power
- Received optical power
- Transceiver supply voltage

It also provides a sophisticated system of alarm and warning flags, which may be used to alert end-users when particular operating parameters are outside of a factory-set normal range.

The operating and diagnostics information is monitored and reported by a Digital Diagnostics Transceiver Controller (DDTC) inside the transceiver, which is accessed through the 2-wire serial interface. When the serial protocol is activated, the serial clock signal (SCL pin) is generated by the host. The positive edge clocks data into the XFP transceiver into those segments of its memory map that are not write-protected. The negative edge clocks data from the XFP transceiver. The serial data signal (SDA pin) is bi-directional for serial data transfer. The host uses SDA in conjunction with SCL to mark

the start and end of serial protocol activation. The memories are organized as a series of 8-bit data words that can be addressed individually or sequentially. The 2-wire serial interface provides sequential or random access to the 8 bit parameters, addressed from 000h to the maximum address of the memory.

For more detailed information including memory map definitions, please see the XFP MSA Specification.

## VII. Mechanical Specifications

Transcom's XFP transceivers are compliant with the dimensions defined by the XFP Multi-Sourcing Agreement (MSA).

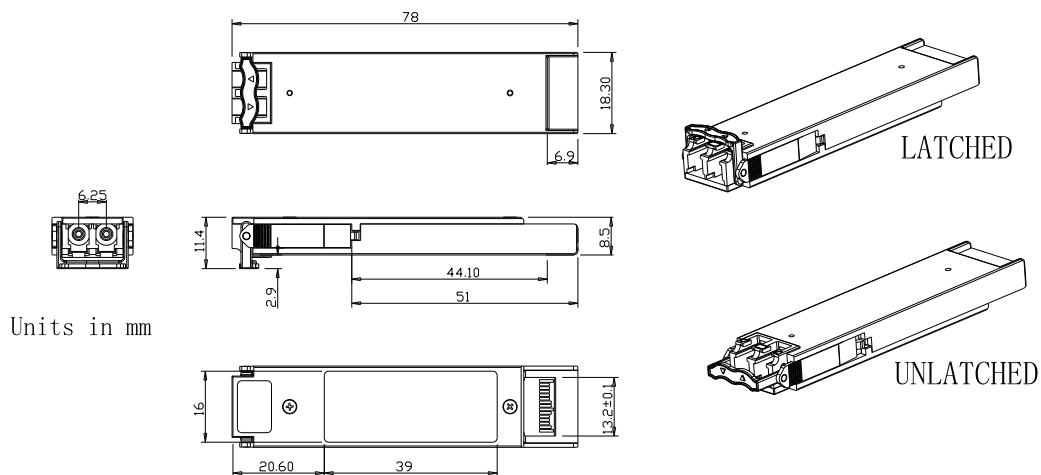

XFP Transceiver (dimensions are in mm)

## VIII. PCB Layout and Bezel Recommendations





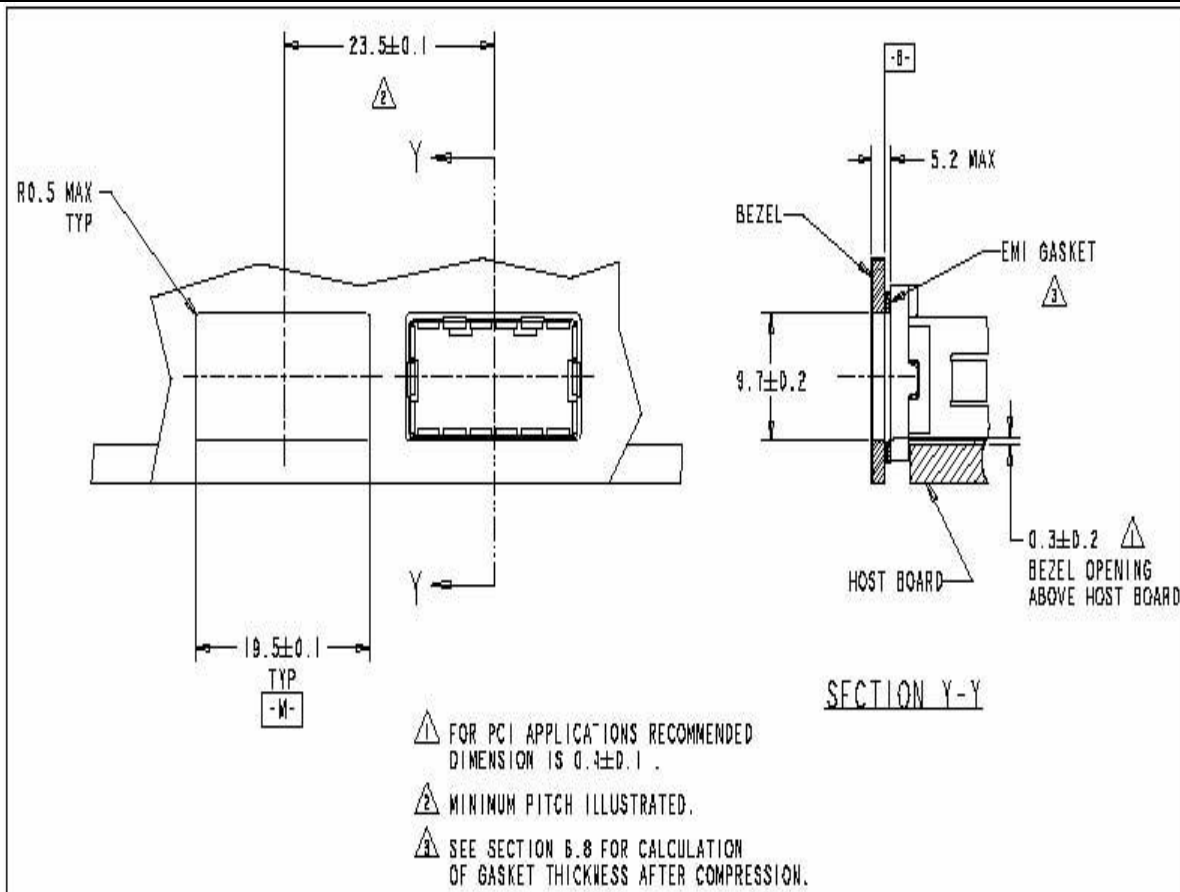

## IX. Regulatory Compliance

Feature	Reference	Performance
Electrostatic discharge (ESD)	IEC/EN 61000-4-2	Compatible with standards
Electromagnetic Interference (EMI)	FCC Part 15 Class B EN 55022 Class B (CISPR 22A)	Compatible with standards
Laser Eye Safety	FDA 21CFR 1040.10, 1040.11 IEC/EN 60825-1, 2	Class 1 laser product
Component Recognition	IEC/EN 60950 , UL	Compatible with standards
ROHS	2002/95/EC	Compatible with standards
EMC	EN61000-3	Compatible with standards

## Appendix A. Document Revision

Version No.	Date	Description
1.0	2010-09-01	Preliminary datasheet

2.0	2011-09-10	Update format and company's logo
3.0	2012-03-29	Update wavelength to 1270~1450
4.0	2013-11-04	add Clasp Color Code to "product selection" table