

# TS-XP-1316-20D

## 16G Fibre Channel SFP+ Transceiver

### Product Features

- Up to 14.025Gb/s bi-directional data links
- Electrical interface specifications per SFF-8431
- Management interface specifications per SFF-8432 and SFF-8472
- SFP+ MSA package with duplex LC connector
- Build-in Dual CDR at 14.025Gb/s and bypass at 4.25Gb/s and 8.5Gb/s
- Uncooled 1310nm DFB Laser
- Up to 25 km on 9/125um SMF
- Single +3.3V power supply
- Class 1 laser safety certified
- 1.8W maximum power consumption with established link
- Operating temperature Options  
- (Commercial) 0°C to +70°C
- RoHS Compliant



### Applications

- Tri Rate 4.25 / 8.5 / 14.025 Gb/s Fibre Channel Rate

### Descriptions

TS-XP-1316-20D SFP+ transceivers, according to 16 Gigabit Small Form Factor Pluggable “SFP+” Multi-Sourcing Agreement (MSA) SFF-8431 Rev. 3.0 and SFF-8472 Rev. 11.0, are designed for use in Fibre Channel links up to 14.025Gb/s data rate and up to 25km link length. They are compatible with FC-PI-5 Rev. 6.10 and SFF-8432.

TS-XP-1316-20D offer commercial operating temperature options.

### Ordering Information

**Table 1. Ordering Information**

Part Number	Transmitter	Output Power	Receiver	OMA Sensitivity @14.025G	Reach	Temp	DDM	RoHS
TS-XP-1316-20D	1310nm DFB	-3 ~ +2dBm	PIN	<-12dBm	25km	0 ~ 70°C	Available	Compliant

### Pin Description

**Table 2. Pin Description**

Pin	Name	Function/Description	Notes
1	VeeT	Transmitter Ground	1
2	TX_Fault	Transmitter Fault (LVTTTL-O) - High indicates a fault condition	2
3	TX_Disable	Transmitter Disable (LVTTTL-I) – High or open disables the transmitter	3
4	SDA	Two wire serial interface Data Line (LVCMOS-I/O) (MOD-DEF2)	4
5	SCL	Two wire serial interface Clock Line (LVCMOS-I/O) (MOD-DEF1)	4
6	MOD_ABS	Module Absent (Output), connected to VeeT or VeeR in the module	5
7	RS0	Rate Select 0 – Not used, Presents high input impedance	6
8	RX_LOS	Receiver Loss of Signal (LVTTTL-O)	2
9	RS1	Rate Select 1 – Not used, Presents high input impedance	6
10	VeeR	Receiver Ground	1
11	VeeR	Receiver Ground	1
12	RD-	Inverse Received Data out (CML-O)	-
13	RD+	Received Data out (CML-O)	-
14	VeeR	Receiver Ground	-
15	VccR	Receiver Power - +3.3V	-
16	VccT	Transmitter Power - +3.3 V	-
17	VeeT	Transmitter Ground	1
18	TD+	Transmitter Data In (CML-I)	-
19	TD-	Inverse Transmitter Data In (CML-I)	-
20	VeeT	Transmitter Ground	1

**Notes:**

1. The module signal grounds are isolated from the module case.
2. This is an open collector/drain output that on the host board requires a 4.7KΩ to 10KΩ pull-up resistor to VccHost.
3. This input is internally biased high with a 4.7KΩ to 10KΩ pull-up resistor to VccT.
4. Two-Wire Serial interface clock and data lines require an external pull-up resistor dependent on the capacitance load.
5. This is a ground return that on the host board requires a 4.7KΩ to 10KΩ pull-up resistor to VccHost.
6. Rate select can also be set through the 2-wire bus in accordance with SFF-8472 v. 11.0, Rx Rate Select is set at Bit 3, Byte 110, Address A2h. Tx Rate Select is set at Bit 3, Byte 118, Address A2h.

**Note:** writing a “1” selects maximum bandwidth operation. Rate select is the logic OR of the input state of Rate Select Pin and 2-wire bus.

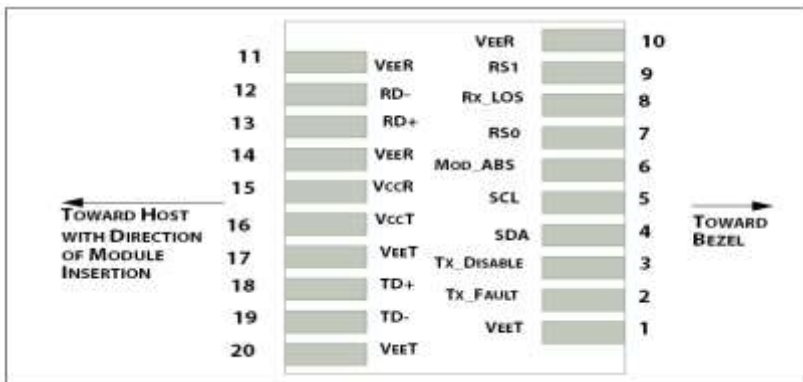

Figure 1. Host PCB SFP+ pad assignment top view

## Absolute Maximum Ratings

Stresses in excess of the absolute maximum ratings can cause permanent damage to the device. These are absolute stress ratings only. Functional operation of the device is not implied at these or any other conditions in excess of those given in the operational sections of the data sheet. Exposure to absolute maximum ratings for extended periods can adversely affect device reliability.

**Table 3. Absolute Maximum Ratings**

Parameter	Symbol	Minimum	Maximum	Unit
Storage Temperature	T <sub>S</sub>	-40	85	°C
Relative Humidity	RH	5	95	%
Supply Voltage	V <sub>CC</sub>	-0.5	4.0	V

## Recommended Operating Conditions

**Table 4. Recommended Operating Conditions**

Parameter	Symbol	Min	Typ	Max	Unit
Operating Temperature	T <sub>C</sub>	0	25	70	°C
Supply Voltage	V <sub>CC</sub>	3.135	3.3	3.465	V
Data Rate	-	-	4.25/8.5/14.025	-	Gb/s

## Transceiver Electrical Characteristics

**Table 5. Transceiver Electrical Characteristics**

Parameter	Symbol	Minimum	Typical	Maximum	Unit	Notes	
Module Supply Current	I <sub>CC</sub>	-		550	mA	-	
Power Dissipation	P <sub>D</sub>	-	-	1800	mW	-	
<b>Transmitter</b>							
Input Differential Impedance	Z <sub>IN</sub>	-	100	-	Ω	-	
Differential Data Input Swing	V <sub>IN, P-P</sub>	180	-	700	mV <sub>P-P</sub>	-	
TX_FAULT	Transmitter Fault	V <sub>OH</sub>	2.0	-	V <sub>CCHOST</sub>	V	-
	Normal Operation	V <sub>OL</sub>	0	-	0.8	V	-
TX_DISABLE	Transmitter Disable	V <sub>IH</sub>	2.0	-	V <sub>CCHOST</sub>	V	-
	Transmitter Enable	V <sub>IL</sub>	0	-	0.8	V	-
<b>Receiver</b>							
Output Differential Impedance	Z <sub>O</sub>	-	100	-	Ω	-	
Differential Data Output Swing	V <sub>OUT, P-P</sub>	300	-	850	mV <sub>P-P</sub>	1	
Data Output Rise Time, Fall Time	t <sub>r</sub> , t <sub>f</sub>	28	-	-	ps	2	
RX_LOS	Loss of signal (LOS)	V <sub>OH</sub>	2.0	-	V <sub>CCHOST</sub>	V	3
	Normal Operation	V <sub>OL</sub>	0	-	0.8	V	3

**Notes:**

- Internally AC coupled, but requires a external 100Ω differential load termination.
- 20 – 80 %.
- LOS is an open collector output. Should be pulled up with 4.7kΩ on the host board.

## Transmitter Optical Characteristics

**Table 6. Transmitter Optical Characteristics**

Parameter	Symbol	Minimum	Typical	Maximum	Unit	Notes
Launch Optical Power, 14.025 Gb/s	P <sub>o,RH</sub>	-3	-	2	dBm	1, 2
Center Wavelength Range	$\lambda_c$	1295	1310	1325	nm	4
Transmitter and Dispersion Penalty @ 8.5 Gb/s	TDP	-	-	3.2	dB	7
Transmitter and Dispersion Penalty @ 14.025 Gb/s	TDP	-	-	4.4	dB	7
Spectral Width	$\Delta\lambda$	-	-	1	nm	4, 5
Optical Rise/Fall Time @ 4.25 Gb/s	t <sub>r</sub> /t <sub>f</sub>			90	ps	8
Optical Return Loss Tolerance	ORLT	-	-	12	dB	-
Pout @ TX-Disable Asserted	P <sub>off</sub>	-	-	-30	dBm	9

**Notes:**

1. Class 1 Laser Safety per FDA/CDRH and EN (IEC) 60825 regulations.
2. High Bandwidth Mode. Class 1 Laser Safety per FDA/CDRH and EN (IEC) 60825 regulations.
3. Low Bandwidth Mode. Class 1 Laser Safety per FDA/CDRH and EN (IEC) 60825 regulations.
4. Also specified to meet curves in FC-PI-5 Rev 6.10 Figures 23, 24, and 25, which allow trade-off between wavelength, spectral width and OMA for 4.25 and 8.5 Gb/s operation.
5. 20dB spectral width.
6. Equivalent extinction ratio specification for Fibre Channel. Allows smaller ER at higher average power.
7. For 14.025 and 8.5 Gb/s operation, Jitter values for gamma T and gamma R are controlled by TDP.
8. Unfiltered, 20-80%. Complies with IEEE 802.3 (Gig. E), FC 4x eye masks when filtered.
9. The optical power is launched into 9/125  $\mu$ m SMF.

## Receiver Optical Characteristics

**Table 7. Receiver Optical Characteristics**

Parameter	Symbol	Minimum	Typical	Maximum	Unit	Notes
Center Wavelength	$\lambda_c$	1260	1310	1370	nm	-
Unstress Receiver OMA Sensitivity = 4.25 Gb/s	RxSENS	-	-	-15.4	dBm	1
Unstress Receiver OMA Sensitivity = 8.5 Gb/s	RxSENS	-	-	-13.7	dBm	1
Unstress Receiver OMA Sensitivity = 14.025 Gb/s	RxSENS	-	-	-12.0	dBm	2
Receiver Overload (P <sub>avg</sub> )	P <sub>OL</sub>	2	-	-	dBm	
Optical Return Loss	ORL	12	-	-	dB	-
LOS De-Assert	LOS <sub>D</sub>	-	-	-16	dBm	-
LOS Assert	LOS <sub>A</sub>	-30	-	-	dBm	-
LOS Hysteresis	-	0.5	-	-	dB	-

**Notes:**

1. Measured with PRBS 2<sup>7</sup>-1 at 10<sup>-12</sup> BER.
2. Measured with PRBS 2<sup>31</sup>-1 at 10<sup>-12</sup> BER.

## General Specifications

Parameter	Symbol	Minimum	Typical	Maximum	Unit	Notes
Data Rate	BR	4.25	-	14.025	Gb/s	1

Bit Error Rate	BER	$10^{-12}$	2
Supported Link Length on 9/125um SMF, 4.25, 8.5, 14.025 Gb/s	LMAX1	- 10	km 3

**Notes:**

1. 4x/8x/16x Fibre Channel compliant.
2. Tested with a PRBS  $2^7-1$  test pattern for 4.25 and 8.5Gb/s operation. Tested with a PRBS  $2^{31}-1$  test pattern for 14.025Gb/s operation.
3. Distances are based on FC-PI-5 Rev. 6.10 and IEEE 802.3 standards.

## Recommended Host Board Power Supply Filter Network

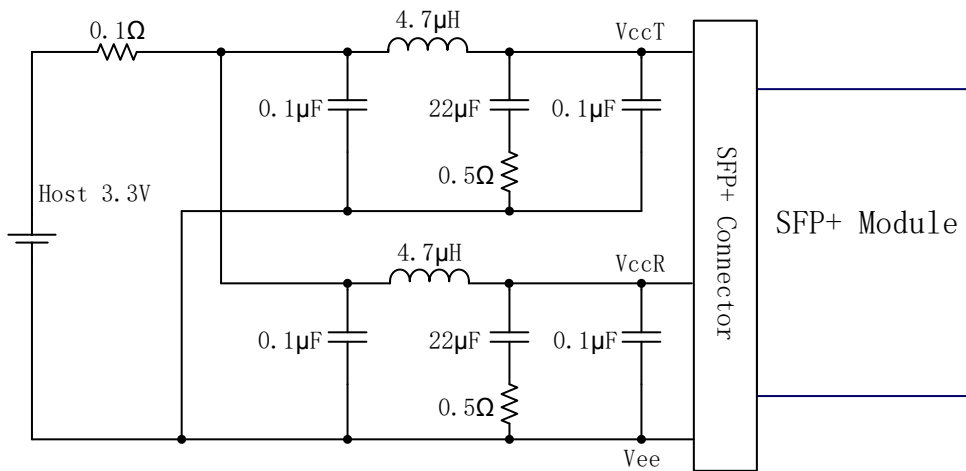

Figure 2. Recommended Host Board Power Supply Filter Network

## Recommended Application Interface Block Diagram

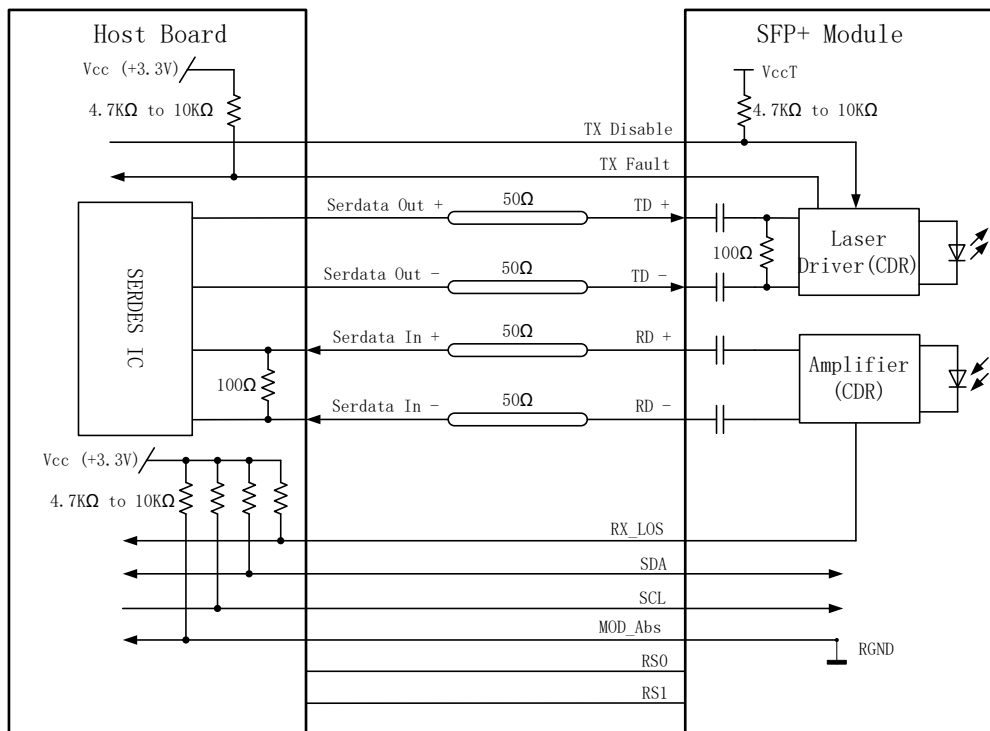

Figure 4. Recommended Application Interface Block Diagram

# Mechanical specifications

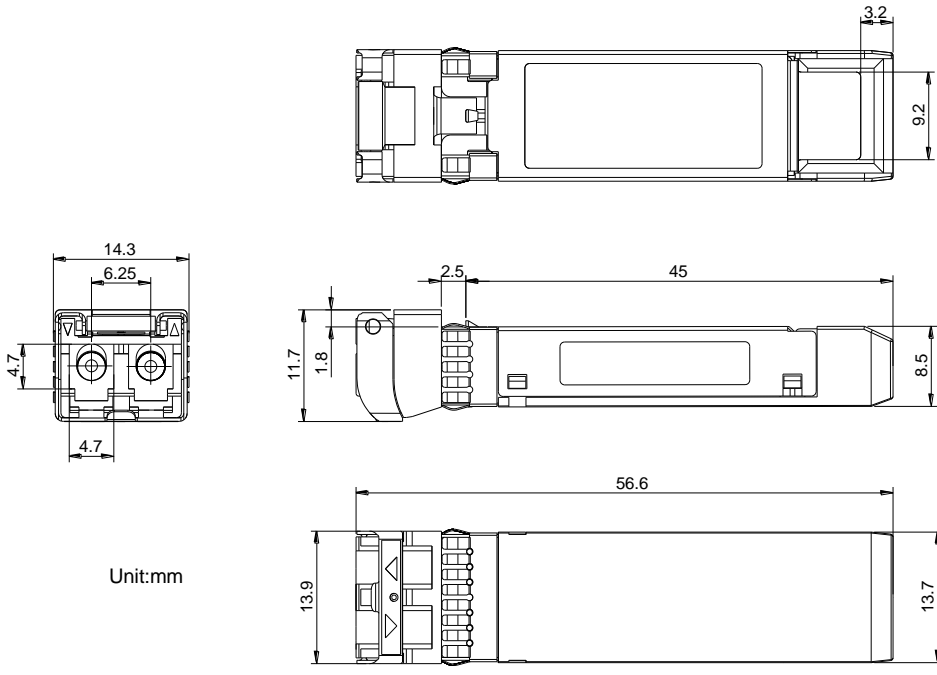
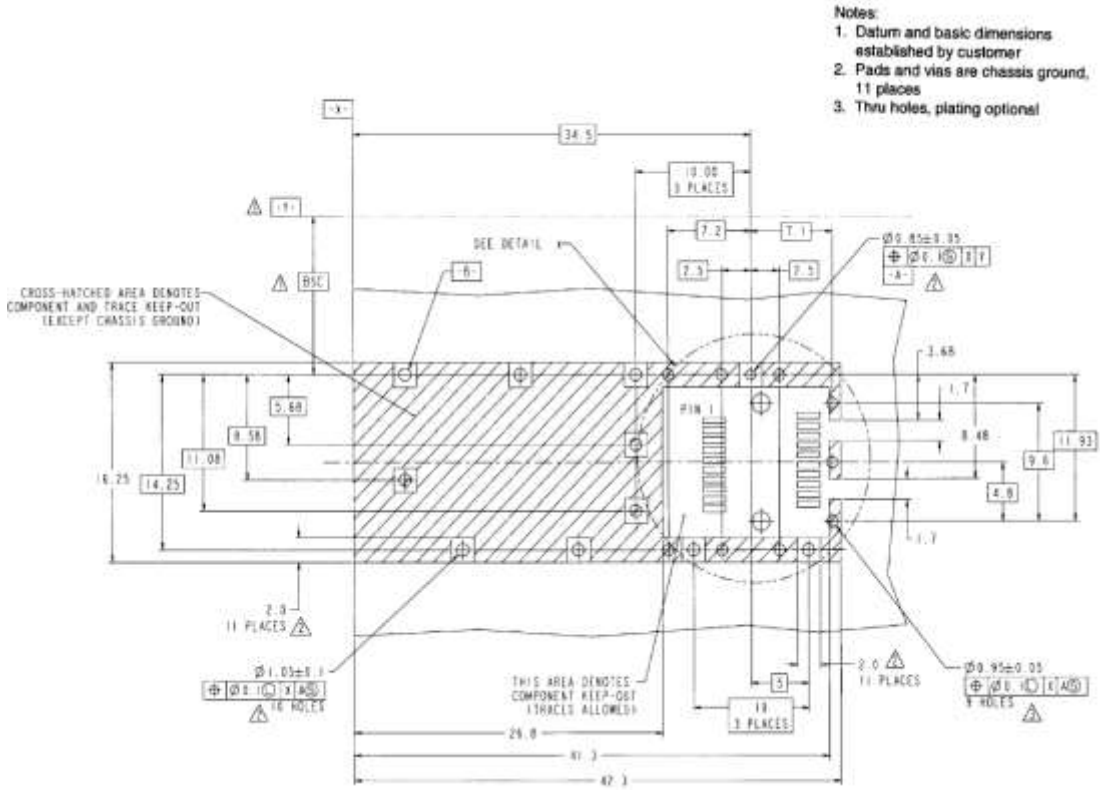

Figure 5. Outline Drawing

# PCB layout recommendation



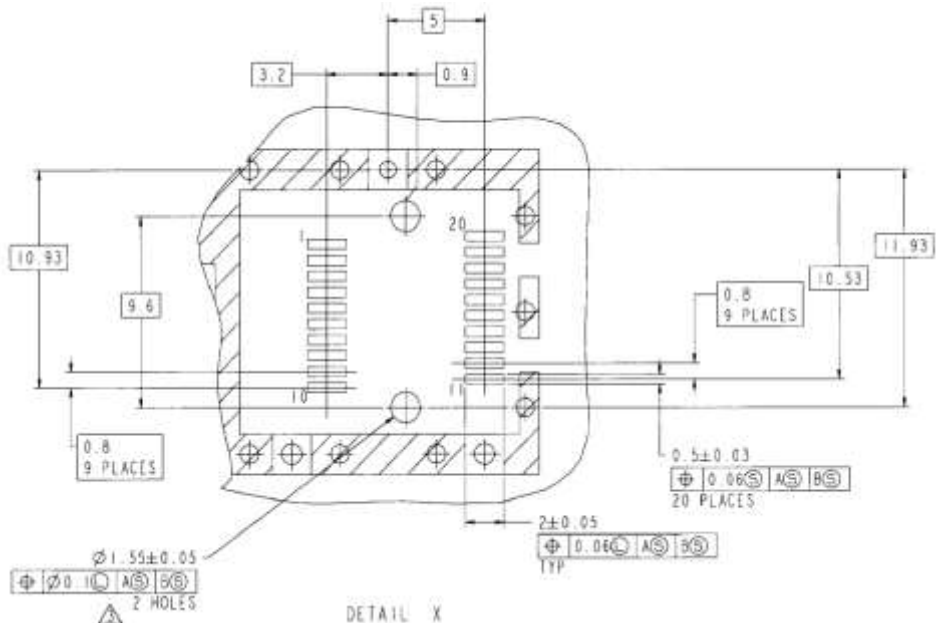

Figure 6. PCB layout recommendation