

## 100G QSFP28 Passive Copper Cable

### Description

The 100GE QSFP28 cable assemblies are high performance, cost effective I/O solutions for LAN, HPC and SAN. The high speed cable assemblies meet and exceed 100 Gigabit Ethernet, InfiniBand EDR and temperature requirements for performance and reliability. The cables are compliant with SFF-8436 specifications and provide connectivity between devices using QSFP ports.

---

### Features

- QSFP28 conforms to the Small Form Factor SFF8665
  - 4-Channel Full-Duplex Passive Copper Cable Transceiver
  - Support for multi-gigabit data rates: 25.78Gb/s (per channel)
  - Maximum aggregate data rate: 100Gb/s (4 x 25.78Gb/s)
  - IEEE 802.3bj 100GEBASE-CR4
  - Copper link length up to 3m
  - Power Supply :+3.3V
  - Low crosstalk
  - I2C based two-wire serial interface for EEPROM signature which can be customized
  - Operating Temperature: 0~ 70 °C
  - RoHS Compliant
- 

### Standards Compliance

- IEEE 802.3bj
  - InfiniBand EDR
  - QSFP28 MSA
  - RoHS Compliant
- 

### Applications

- 100 Gigabit Ethernet
- Fiber Channel over Ethernet

- Data storage and communication industry
- Switch / router / HBA
- Enterprise network
- SAN
- Data Center Network

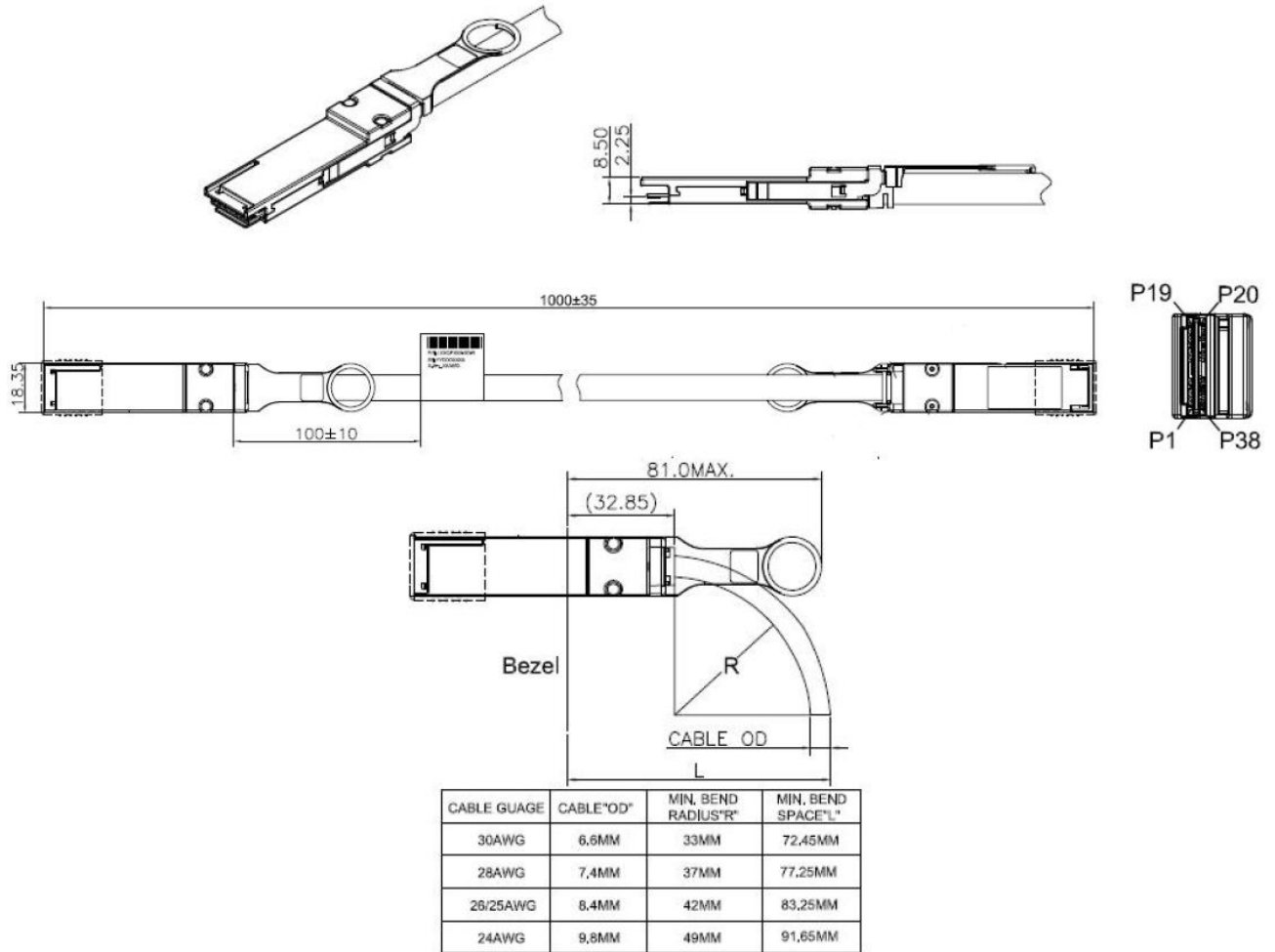

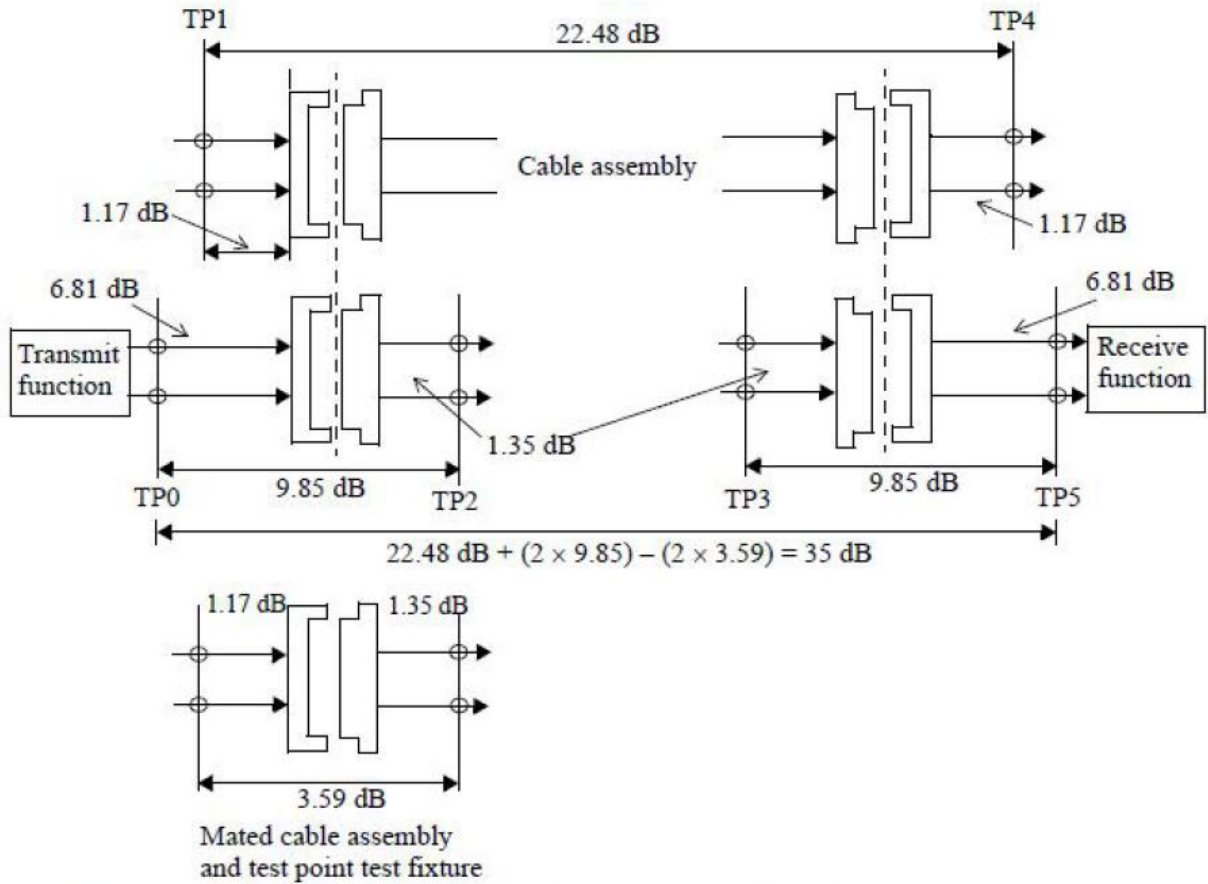

NOTE—The connector insertion loss is 1.07 dB for the mated test fixture. The host connector is allocated 0.62 dB of additional margin.

**Figure 92A-2—35 dB channel insertion loss budget at 12.8906 GHz**

# 100% Test and high performance

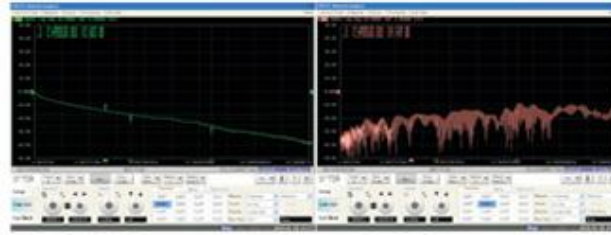

Differential Return loss

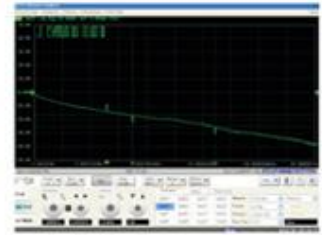

Insertion loss



Common-mode to common-mode output return loss

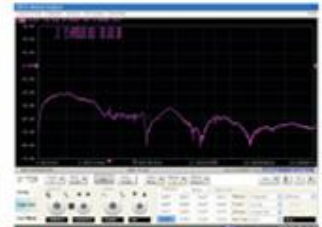

Differential to common Mode Conversion Loss



Differential to common-mode return loss